



Integral Kit Instructions

**For Fisher & Paykel
Cabinet widths of
525, 635, 680, 790 mm wide
For curved door Models**

Series B, C, D & G

Manual 814980

Updated August 2007

IMPORTANT

If your refrigerator has this type of front roller assembly as shown in diagram 1, then these are the **INCORRECT** Built - in Kit instructions and dimensions you are following. Please use Built-in Kit instructions 873918.

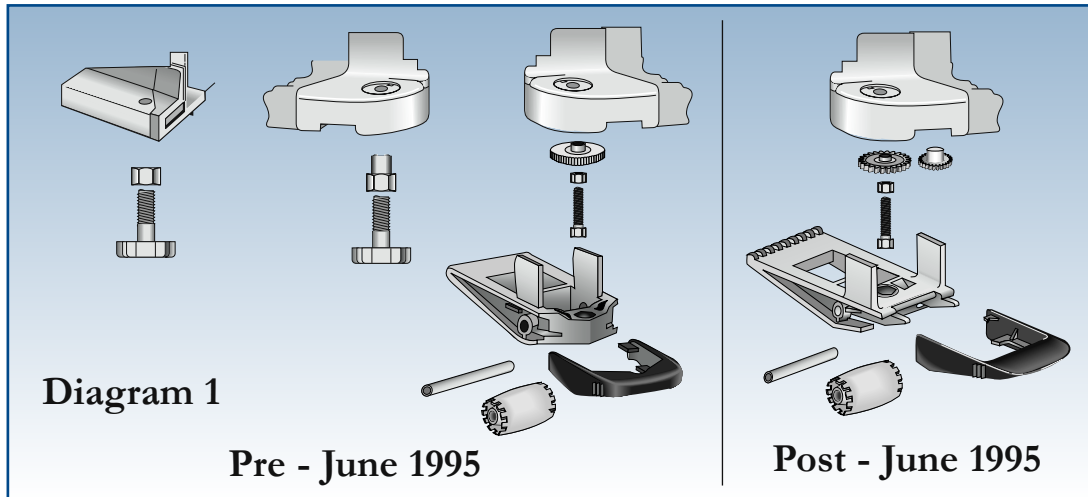

Kit Part Number 874561
H-Drawer Kit 876811

1985 G, H, A, J, K, L, M, P, Q, R series to June 1995

Kit Part Number 874560
H-Drawer Kit 876811

1995 R series July onward

Curved Door Models



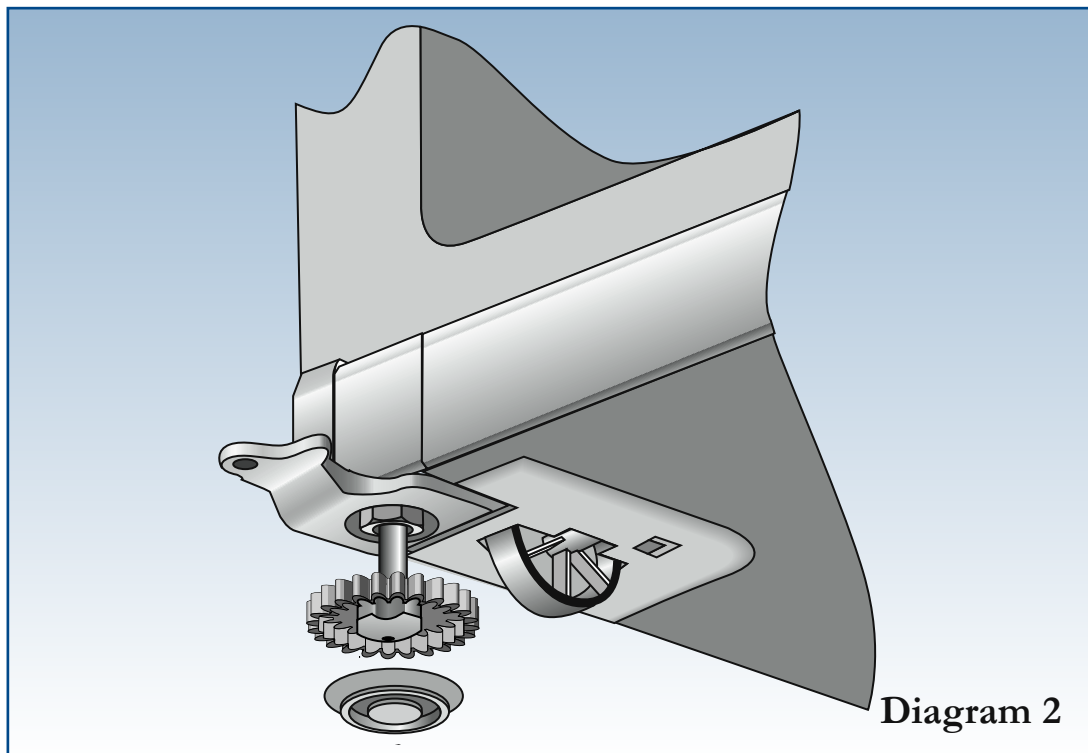







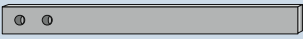

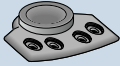
If your refrigerator has this type of front roller assembly as shown in diagram 2, then these are the **CORRECT** instructions.



Kit Part Number 814990
H-Drawer Kit 880800

1998 B series October onward

Parts supplied with Built-In kit Part No. 814990

Part	Quantity	Description	Part no.
	4	Rail slide	880791
	4	Bracket slide	880792
	2	Foot Integration	880793
	8	Cap Elliptical for foot integration	880794
	2	Spacers 20mm	880795
	8	Screw A: (#8X 3/4 CSK POSI)	880796
	2	Screw B: (#8X30 CSK POSI)	880797
	8	Screw C: (#8X40 CSK POSI)	880798
	4	Screw D: (#8X 1/2 PAN PH)	900373
	1	Endcap Blank RH	883715
	1	Endcap Blank LH	883716
	5	Plug	880618

Ventilation Grill (Not part of the kit, order separately, recommended for integration of 790 wide models)

	1	Ventilation grill (Not part of the Kit order separately)	873917
---	---	---	--------

Internal dimensions					
Model 525	Width (A)	Depth (B)	Height (C)	PC/FC Centre line (D)	H-Drawer (E)
P120	600	600	840		
C190, E150	600	600	1228		
C170T, E169T	600	600	1228	811	
C270, E210	600	600	1616		
E249T	600	600	1616	1200	
E240B	600	600	1616	811	

Model 635					
E331T	735	730	1446	971	
E373/C373, E308	735	730	1446		
E381T	735	730	1616	1141	
E372B	735	730	1616	652	
E411T	735	730	1716	1240	
E402B	735	730	1716	652	
E415H	735	730	1716	1240	480
E450/C450, E388	735	730	1716		

Model 680					
E413T	780	730	1616	1141	
E406B	780	730	1616	652	
E440T	780	730	1716	1240	
E442B	780	730	1716	652	

Model 790					
E521T	890	730	1716	1240	
E522B	890 (35 ¹ / ₃₂ "	730 (28 ³ / ₄ "	1716 (67 ⁹ / ₁₆ "	652 (25 ¹¹ / ₁₆ "	

Internal Dimensions width of the built in cabinet is as follows

790/680/635 models

Cabinet internal width = Product width (790, 680 or 635) + 80mm (3¹/₈") hinge side and 20mm (3/4") door open side.

525 models

Cabinet internal width (600mm) = Product width (525mm) + 55mm hinge side and 20mm door open side. Only 90° hinges are to be used. See hinging section (pg 5)

For height dimensions of the doors don't forget to take into account the thickness of the material used in the floor and roof of the built in cabinet as the dimensions stated are all internal.

Note: All dimensions shown are internal.

Installation dimensions

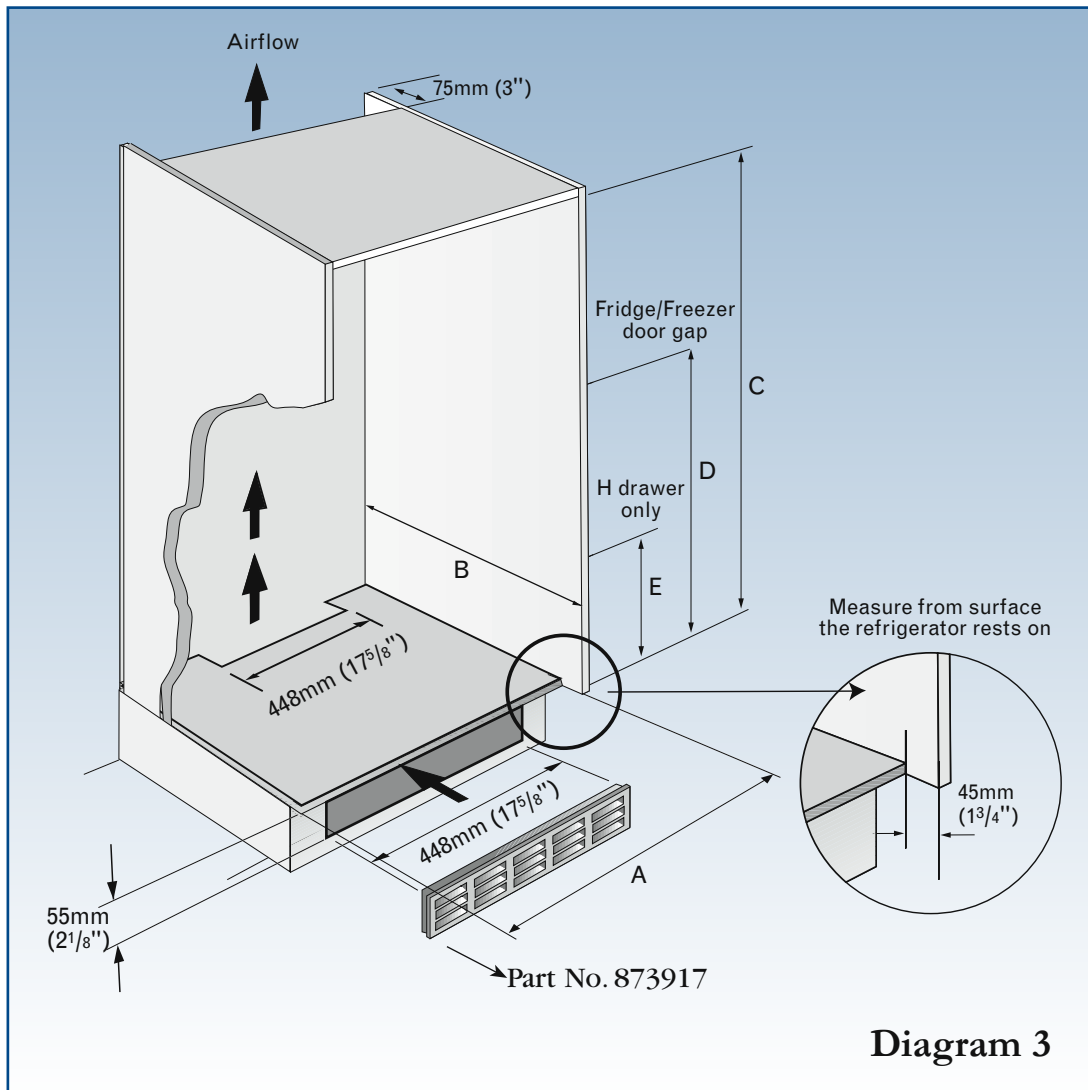

For Insert Doors add 30mm (2") to A and B

Cabinet Construction

IMPORTANT NOTICE

For a refrigerator to function to its optimum standard it requires a certain amount of air clearance around the cabinet. With integration the cabinet is essentially sealed up. As a result, the products energy, temperature and/or basic performance could be affected as compared to a freestanding product.

If there are any issues with the products performance due to integration, this is at the customers risk.

This diagram depicts the use of a ventilation grill. We recommend the use of this grill when integrating 790 wide models. This grill is not included in this kit and can be ordered as Part 873917.

Hinges

Illustrated below are some of the types of hinging that can be used.

790, 680 & 635 Models

It is recommended that 110° hinges having a low profile are used, either full or half overlay such as the GRASS brand. We recommend the use of hinges that can carry a high load, especially when integrating 790 models.

For 525 Models, we recommend only 90° hinges (to allow fitment in 600 modular units).

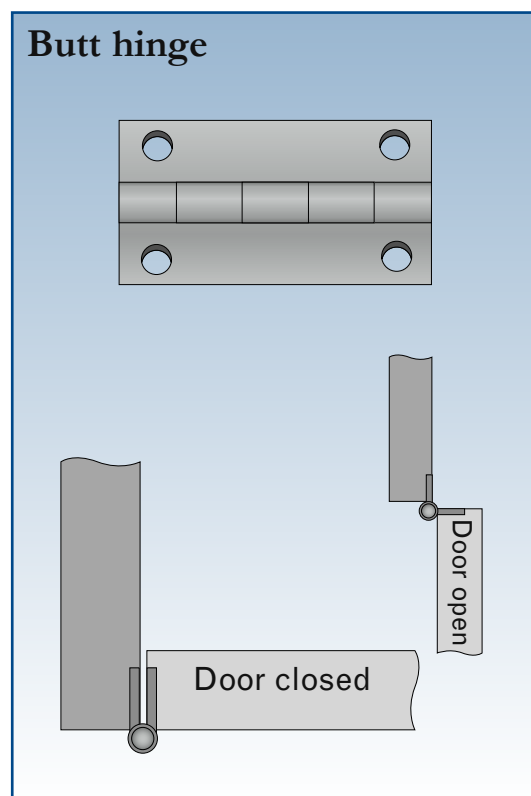
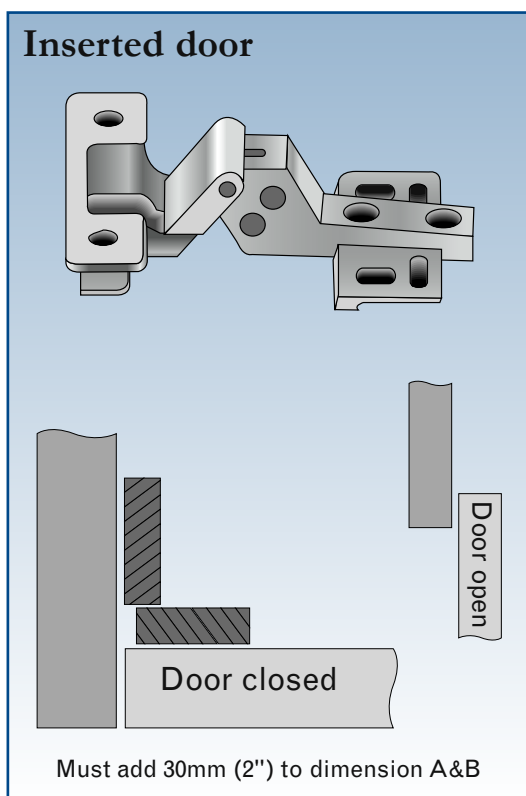
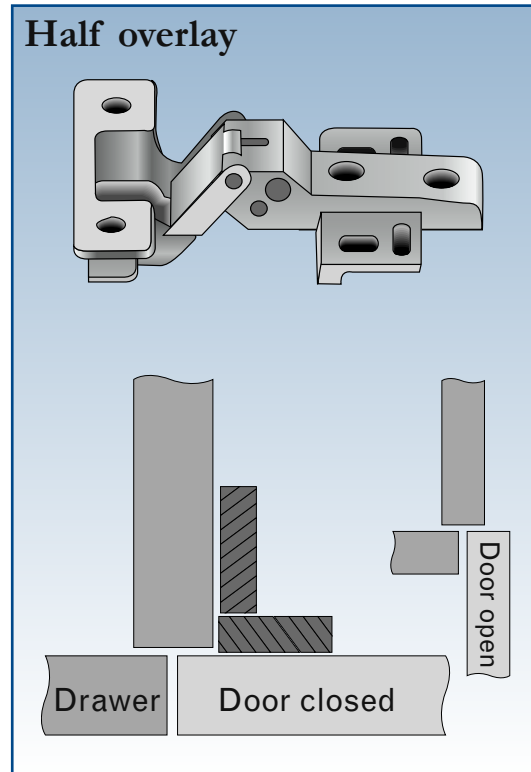
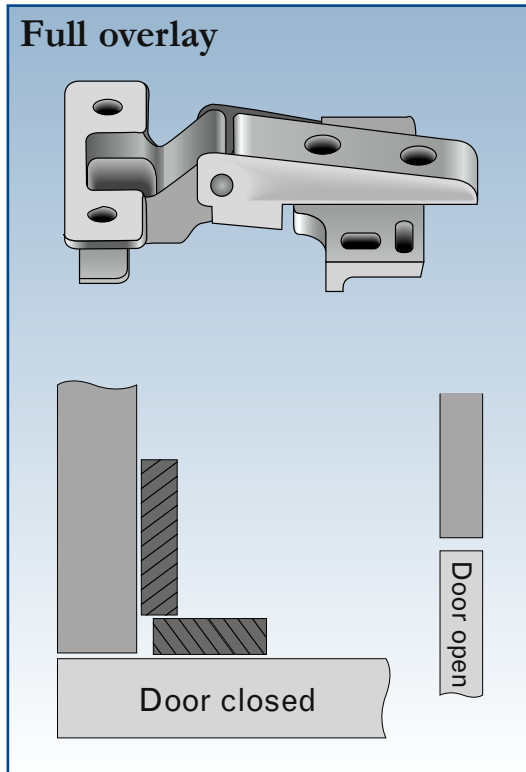

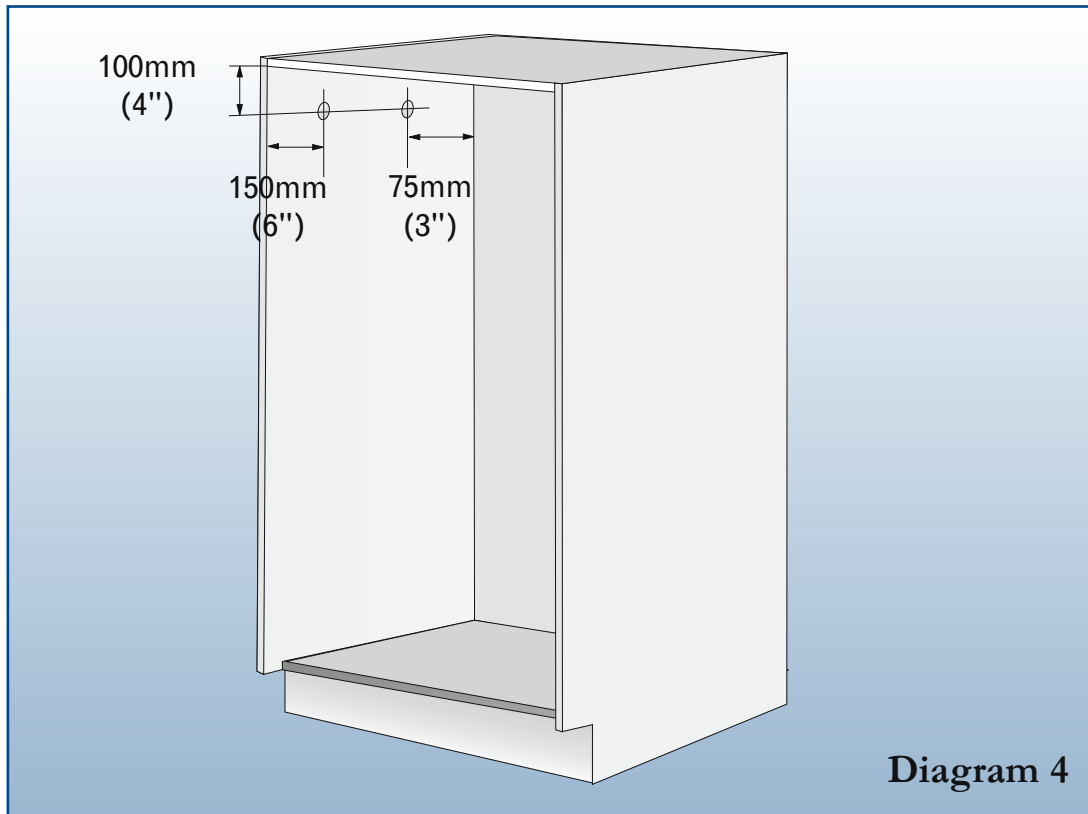

Diagram 4

1 Prepare Refrigerator for Installation

- a) Check that the internal cupboard dimensions are correct (see page 3)

Unpack refrigerator protecting the floor and/or paint work from damage.









- b) Check that refrigerator door is hinged on desired side. Refer to use & care booklet for instructions to change hinge side.

Remove the door handles on models 635, 680 & 790.

Fit the door end cap blank to the corner of the door. Fit small plugs to the screw holes left when the door handle was removed.

Using screw B, attach spacers to the side of the built in cabinet on the side without hinges. They should be positioned approximately 100mm (4") from the top front, 150mm (6") from the front edge, and 75mm (3") rear corners of the refrigerator cabinet. These spacers along with the foot integration bracket maintain an even gap of 20mm (3/4") between the cupboard and the refrigerator side.

How To Remove Refrigeration Handles

<p style="text-align: center;">Tasman Models With Plastic Handles</p> 	<ol style="list-style-type: none"> 1. There are 3 screws on the PC door and two on the FC door that hold on the Tasman handles. 2. Remove cap-covering screws and remove screws, as shown below 3. Remove handle 
<p style="text-align: center;">Curved Door Models Elegance Inox</p> 	<ol style="list-style-type: none"> 1. Remove door end cap to expose the door handle plate. 2. Remove screw which holds handle bracket as shown in Photo A 3. Remove plate, (Photo B) pull handle away from door. 4. Pull bottom of handle from door. <p style="text-align: center;">Photo A Photo B</p>  
<p style="text-align: center;">Flat door models Designer</p> 	<ol style="list-style-type: none"> 1. Remove small screw from underneath of the handle. (Refer Photo C) 2. Use a 2.75mm Allen Key. 3. Once screws have been removed handle bosses can be removed from the door.  <p style="text-align: center;">Photo C</p>
<p style="text-align: center;">Flat doors Designer 2 Handles</p> 	<p>Note: The designer 2 Handle has a large handle end therefore uses a larger grub screw.</p> <ol style="list-style-type: none"> 1. Using a 2.75mm Allen key remove the grub screw (refer Photo D) from the underneath of the handles. 2. Remove the handles. 3. Remove handle bosses.  <p style="text-align: center;">Photo D</p>

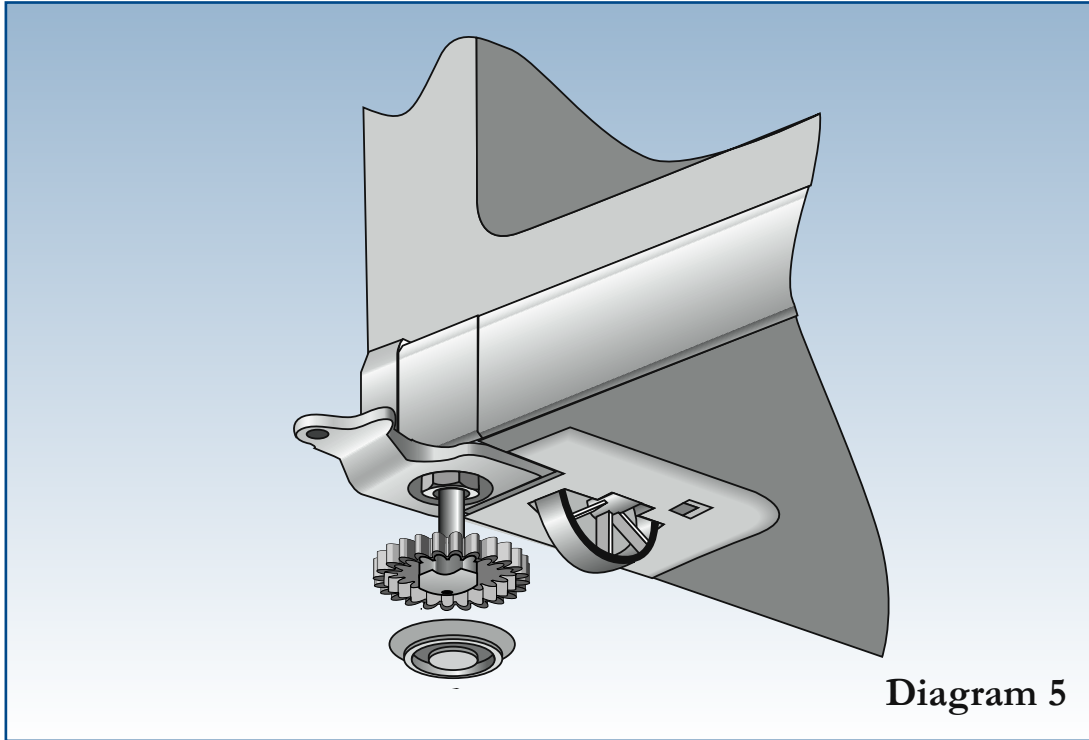

Diagram 5

Tilt the product back and remove the levelling foot circular base insert from the front levelling feet, a small flat blade screw driver can be used.

Lift the product into the cabinet

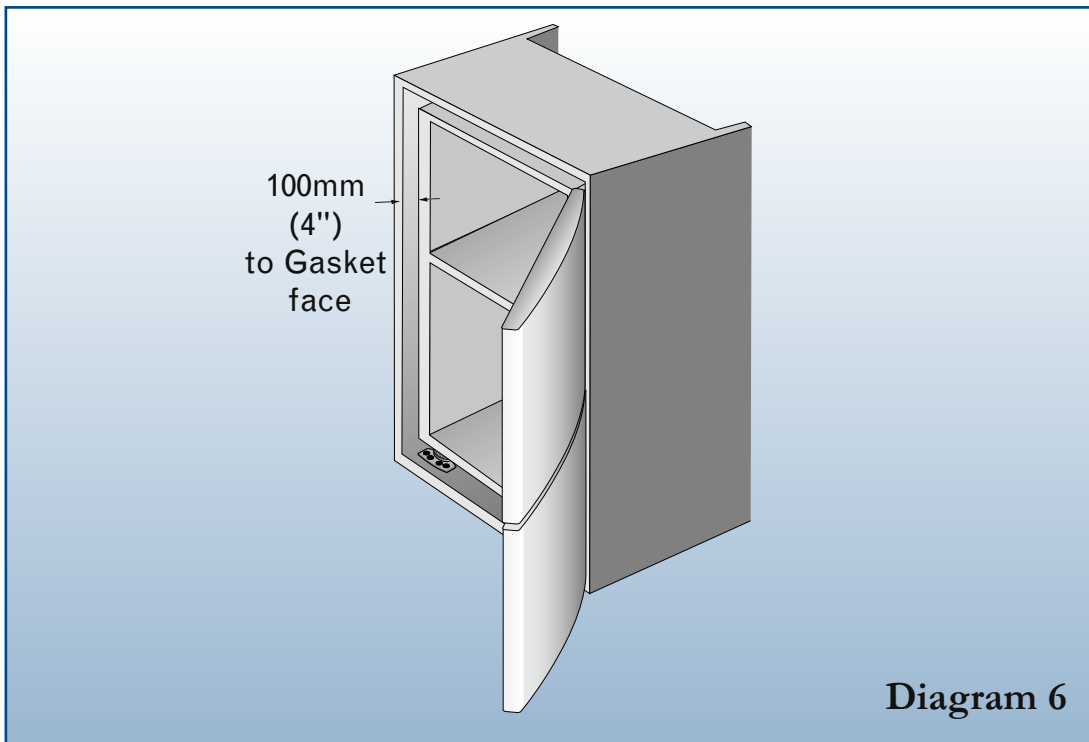
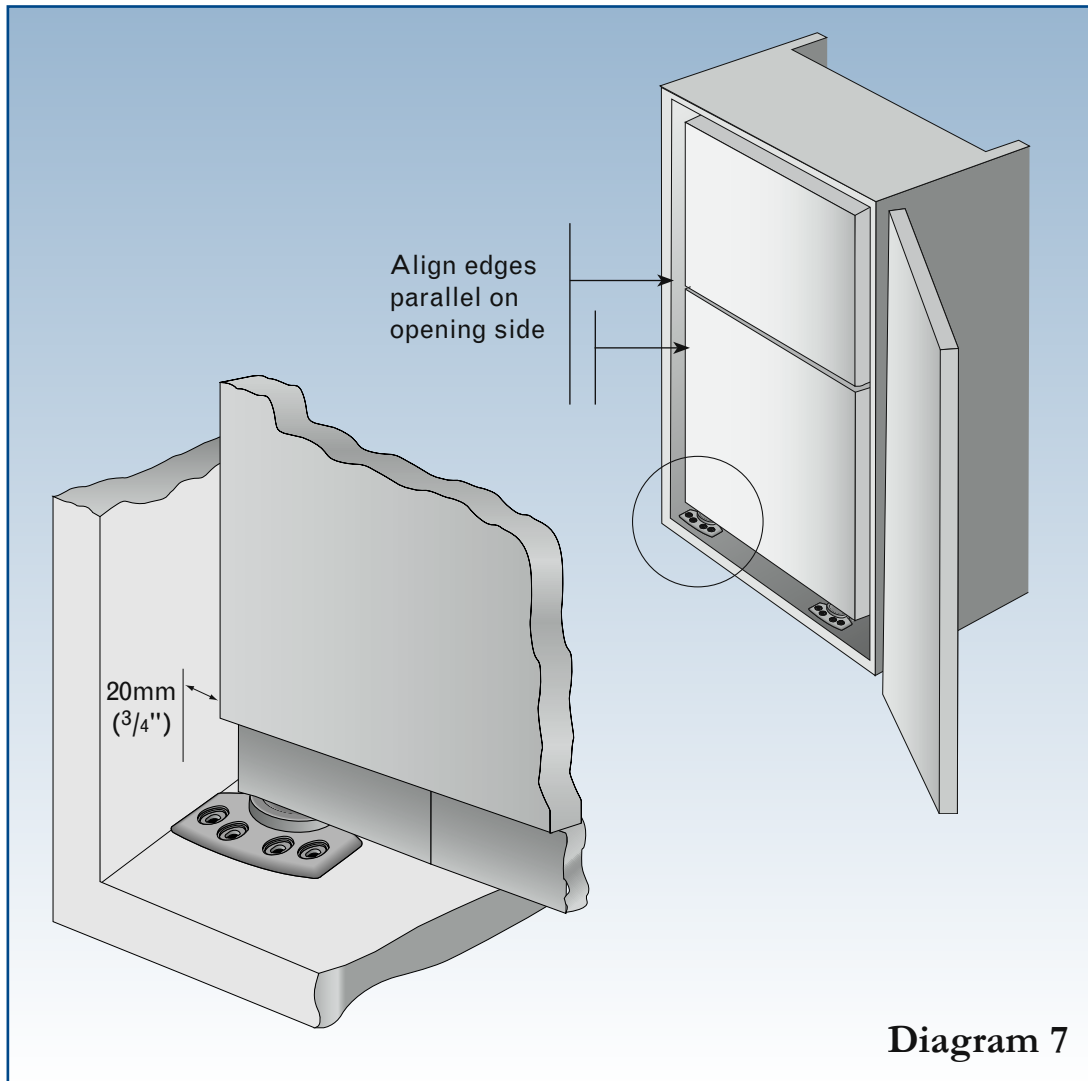

Diagram 6

Lift the front edge of the product and slide the integration foot under the levelling foot.

Push the product back to allow the outer cabinet door to close. This will be approximately 100mm (4") from the front edge of the built in cabinet to the gasket face of the refrigerator.



Align Refrigerator in Cupboard

Slide the product toward the opening side of the cupboard. The integrated foot should touch the cupboard wall. This will set a 20mm (3/4") gap between cupboard and refrigerator.

Adjust the product so it is parallel to the cabinet front to back and side to side.

This is obtained by the adjustment of the front levelling feet.

WARNING. Please be advised that adjustment of glass shelves is not possible once the refrigerator has been integrated.

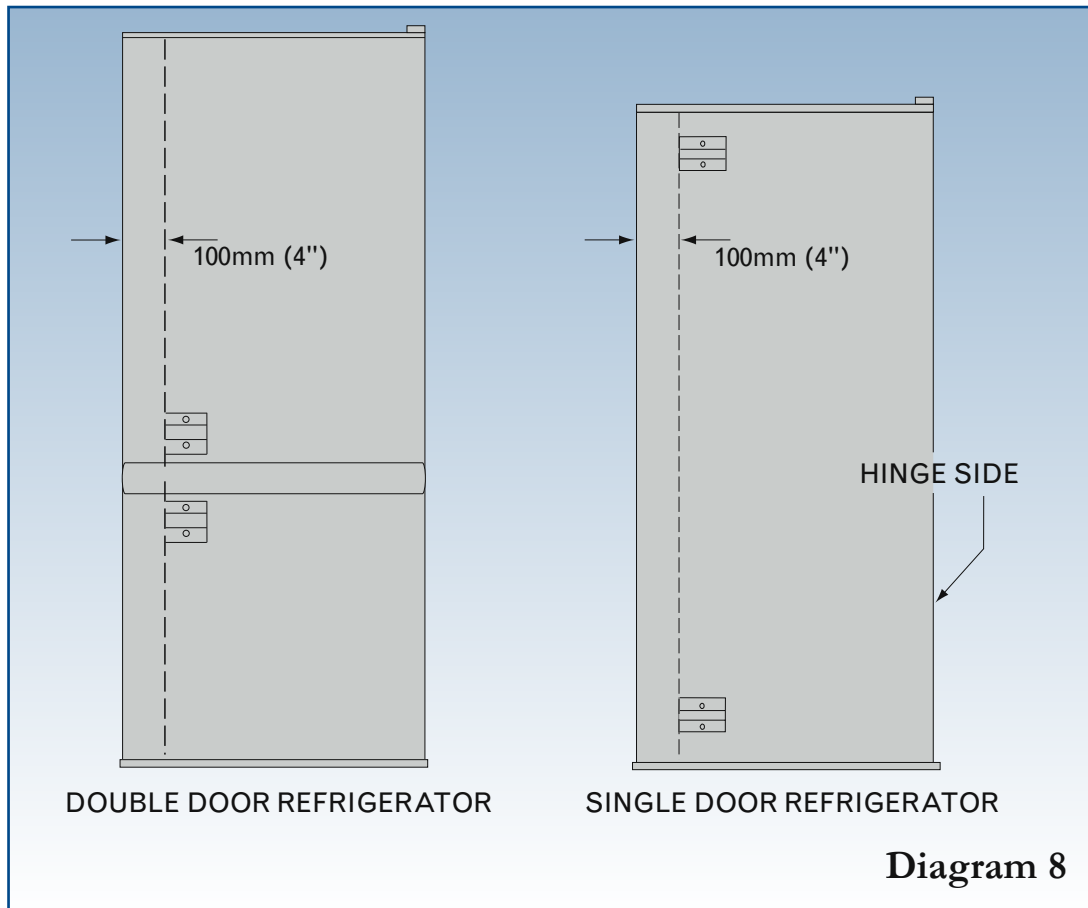

Attach Slide bracket to Refrigerator Doors

Attach the slide bracket to the side of the door opposite to the hinges, 100mm (4") in from the edge.

On a two door refrigerator use one slide bracket per door. If integrating a 790 model, we recommend using 2 slide brackets per door - one near the bottom of the door & one near the top of the door to evenly distribute the weight. The brackets should be attached to the opening side of the doors near the refrigerator and freezer compartments.

On a single door refrigerator use one slide bracket at each end of the door.

Screw brackets firmly into the steel door face using countersunk screw C.

Attach Slide Bracket to Cupboard Door

- a) Open both cupboard and refrigerator door to 110° degrees. (525 Compact models to 90°)
- b) Put slide bracket in retainer, 120mm (4³/₄" approx past refrigerator door. (diagram 9).
- c) Check that screw A (supplied with kit) will not penetrate front surface of cupboard door (diagram 10).
- d) Screw slide bracket level into the cupboard door using screw A (supplied with the kit)
- e) Check slide mechanism does not bind through swing of door.
- f) Repeat for second bracket.

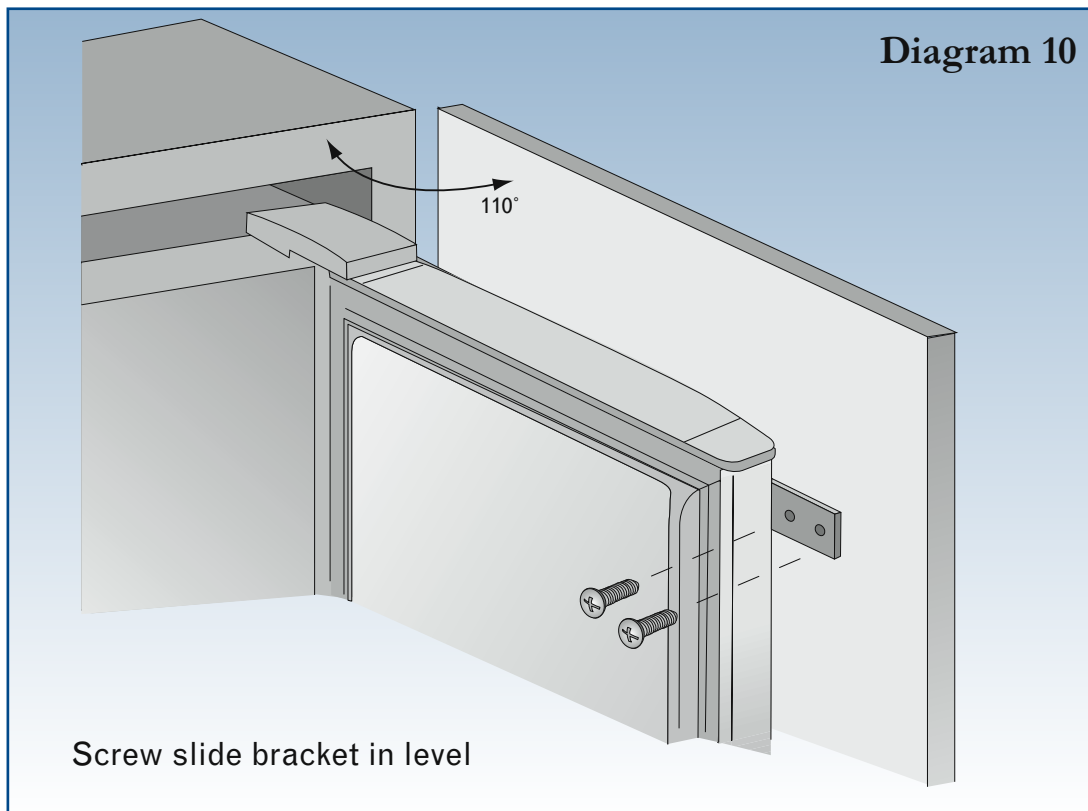
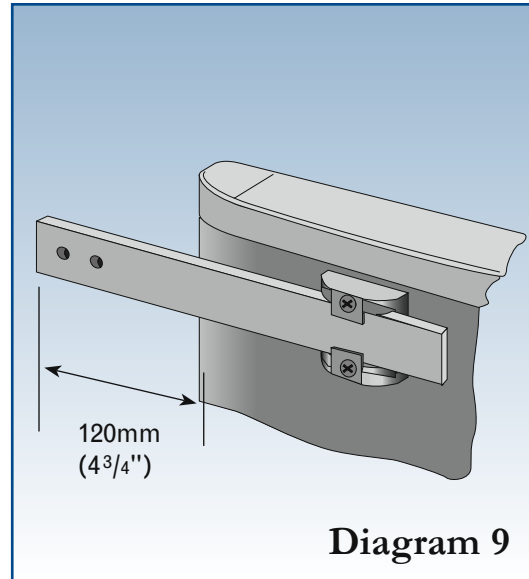

IMPORTANT

Ensure that refrigerator doors are able to close fully and seal around the flexible gasket on the refrigerator/freezer. This is to prevent air leaks and icing problems

Complete Installation



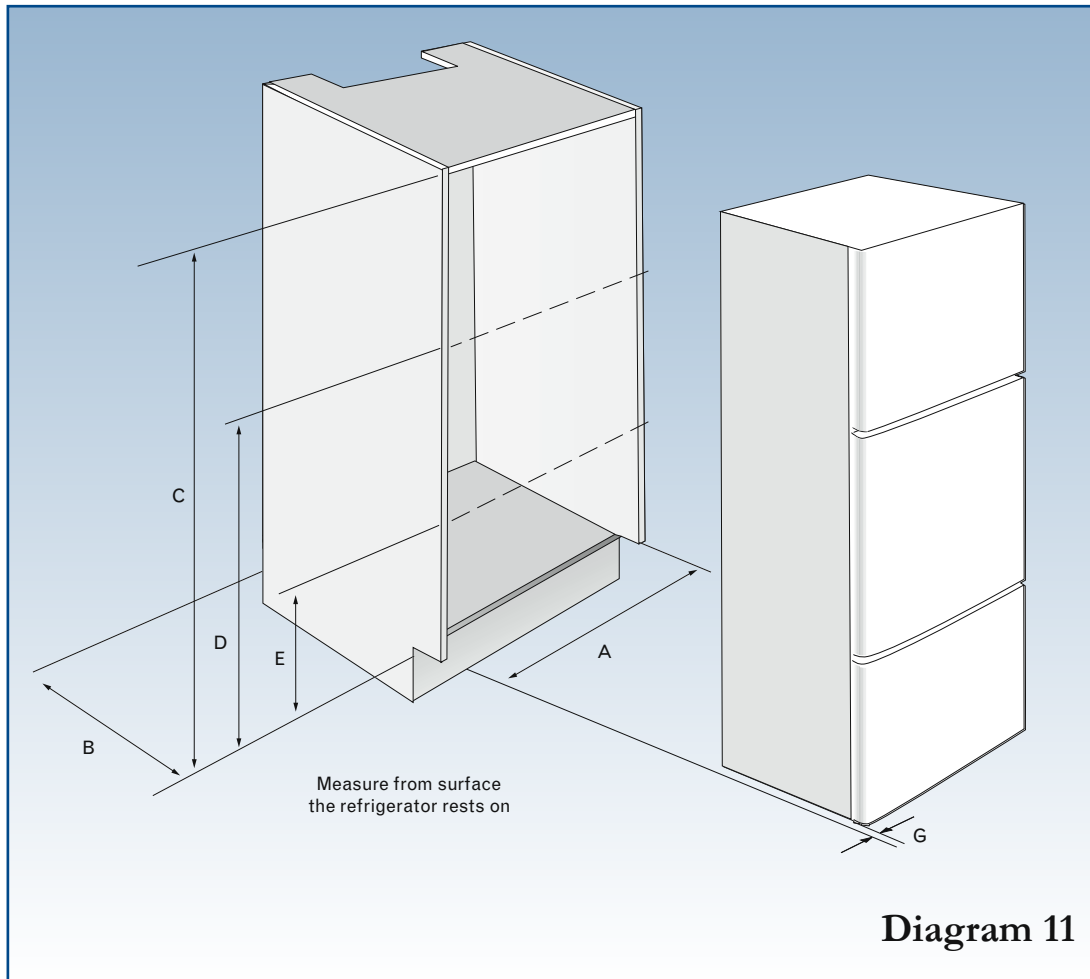

- a) If installing a H model with a roll-out humidity drawer then fit the outer door panel following the instructions in the next section.
- b) Otherwise complete the installation by screwing the foot integration into position, using screw (D) (supplied with the kit), and the cap elliptical to cover the screws.

Humidity Drawer Installation

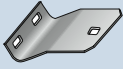

Dimensions	
Model	E415H
Dim A (mm)	735
Dim B (mm)	730
Dim C* (mm)	1716
Dim D (mm)	1240
Dim E* (mm)	480
Dim G (mm)	20
If 'O' overlay doors are used add 30mm to dimension 'A' and 'B'	
Specification subject to change without notice	

Additional humidity drawer kit Part No. 880800

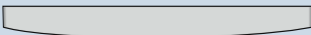
Part	Quantity	Description	Part no.
	4	Bracket	880801
	12	Screw E: (#6X 1/2 PAN PH)	SP0008
	1	Endcap Blank RH white	883715
	1	Endcap Blank LH white	883716
	1	Endcap Outer 635 white	883670

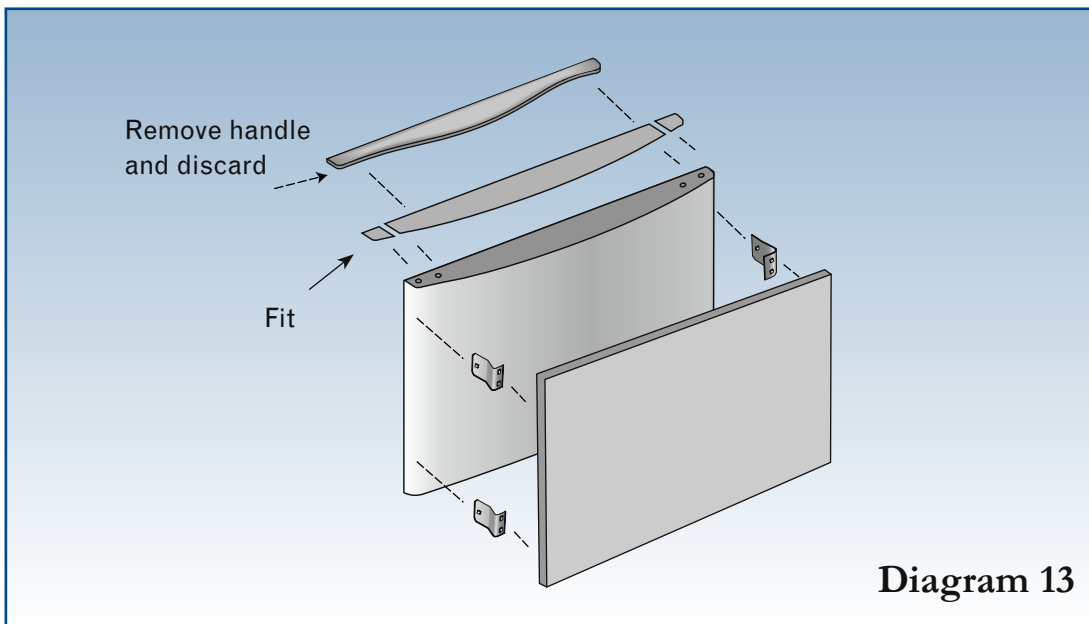
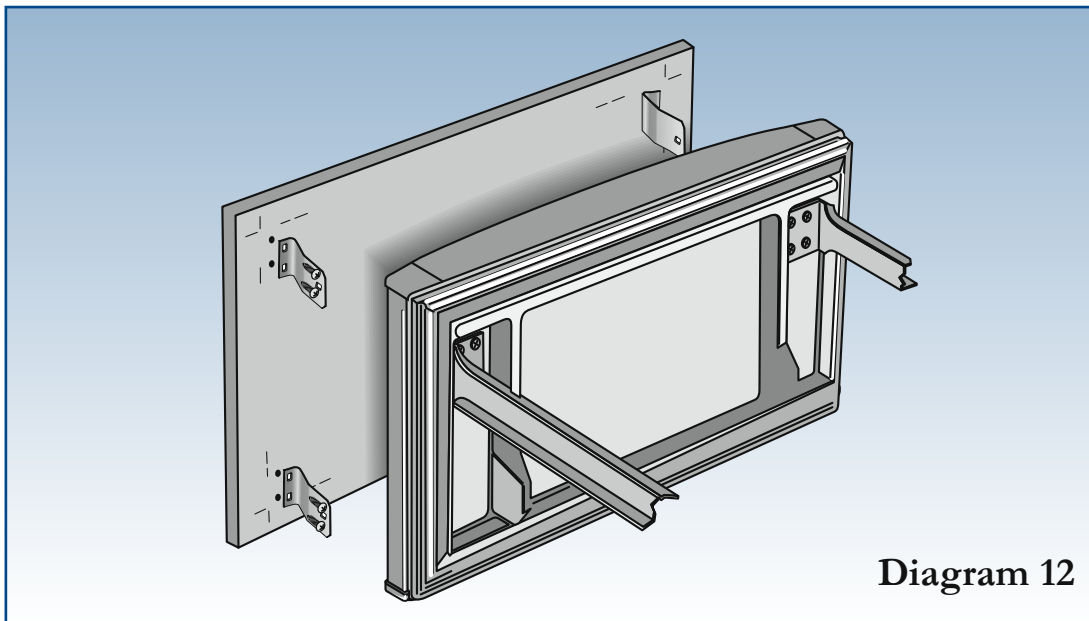

Humidity Drawer Installation

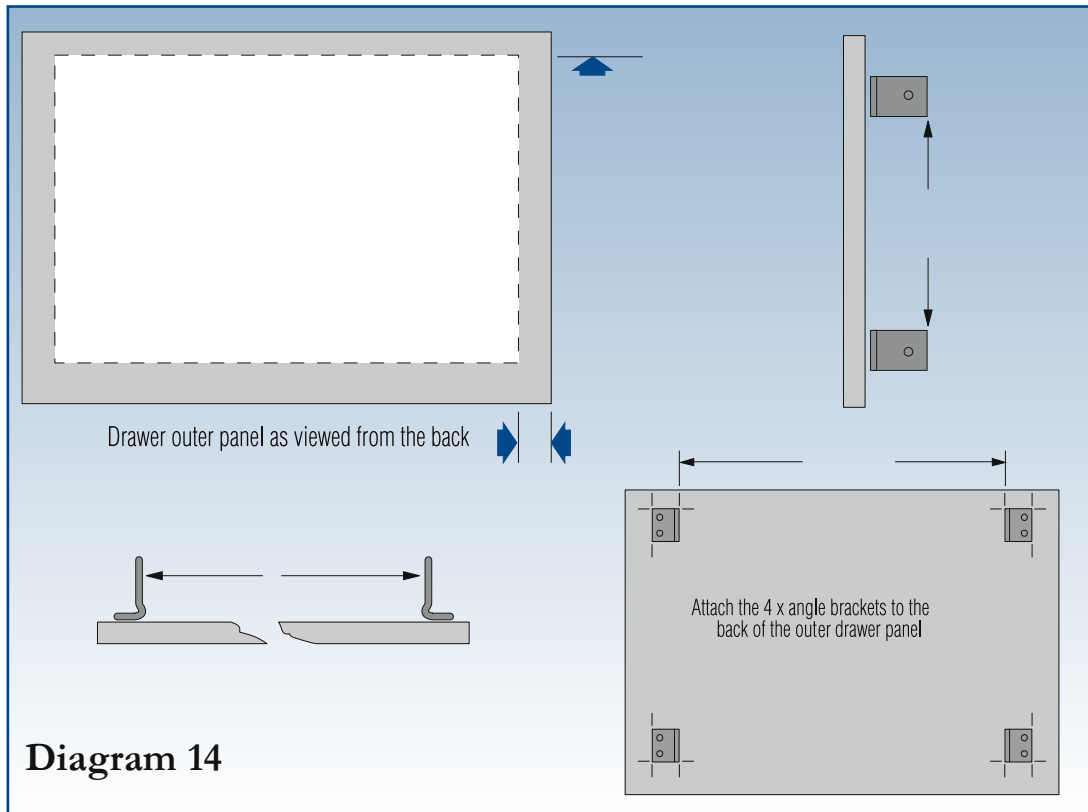

Diagram 14

Assembly instructions for 'H' drawer built-in kits

- The "H" drawer of this type of refrigerator is attached to the outer door panel of the built-in cabinet by means of four angle brackets attached to the back of the outer drawer front.

1. Fit the Refrigerator as previously instructed into the built-in cabinet, and attach the other door.
2. Remove the "H" Drawer handle from the top of the "H" Drawer and discard. Fit the endcap outer and end cap blanks provided in the "H" Drawer kit.
3. Take and mark the position of the outer drawer front drawer panel against the "H" Drawer itself, note the clearance needed between the Drawer front panel and the door above. (Masking tape is ideal to place over the area to be marked).

The "H" Drawer can be removed from the refrigerator completely by pulling it out to it stops and then lifting it up and pulling forward.

4. Place and mark drawer front mounting brackets at each corner of the "H" Drawer position.
5. Attach the mounting bracket to the back of the outer door panel.

Note: Check the length of the mounting screw E so that it doesn't go right through the outer drawer panel.

6. The outer drawer panel can now be attached to the "H" Drawer itself by screwing through the side of the "H" Drawer
7. Adjustment in/out is made by the slots in the brackets.

IMPORTANT: Ensure that refrigerator doors are able to close fully and seal around the flexible gasket on the refrigerator\freezer. This is to prevent icing problems.