



# Evacuated Tube Solar Hot Water System

## Owners Manual



**Version 1.1**

**07-Nov-07**

Hills Industries Limited (ABN 35 007 573 417)  
944-956 South Road, Edwardstown, South Australia 5039  
Website: [www.hillssolar.com.au](http://www.hillssolar.com.au) Email: [info@hillssolar.com](mailto:info@hillssolar.com)  
Copyright © 2007 Hills Industries Limited



## TABLE OF CONTENTS

<b>Section</b>	<b>Page</b>
<b>1 INTRODUCTION.....</b>	<b>5</b>
1.1 Important forms you need to complete.....	5
1.2 Document overview .....	5
<b>2 KEY FEATURES AND BENEFITS .....</b>	<b>6</b>
2.1 Key features.....	7
2.2 Hills Solar storage tanks and boosting .....	8
<b>3 IMPORTANT INFORMATION.....</b>	<b>9</b>
3.1 Australian/New Zealand Standards .....	9
3.2 Qualified installers .....	9
3.3 Water temperature .....	9
3.4 Water flow .....	9
3.5 Water quality .....	9
3.6 Corrosion from bore water and chlorinated pools and spas .....	9
3.7 Protection against freezing .....	9
3.8 Collector gross weight and dimensions (filled).....	10
3.9 Stagnation and excess heat .....	10
3.10 Hail-prone areas .....	11
3.11 Mounting frame.....	11
<b>4 OWNER MAINTENANCE .....</b>	<b>14</b>
4.1 Cleaning.....	14
4.2 Leaves.....	14
4.3 Broken tube replacement.....	14
4.4 Evacuated tube heat pipe insertion .....	15
4.5 Post installation cleaning.....	16
4.6 Insulation .....	16
4.7 Other components.....	17
<b>5 TROUBLESHOOTING .....</b>	<b>18</b>
5.1 No Hot Water .....	18
5.2 Reduced Solar Contribution .....	18
5.3 DIY Investigation .....	18
5.4 Regular Releasing of Hot Water .....	19
5.5 Safety Precautions .....	19
<b>6 WARRANTY .....</b>	<b>20</b>
6.1 Warranty Conditions .....	20
6.2 Warranty Exclusions .....	21
<b>7 FREQUENTLY ASKED QUESTIONS.....</b>	<b>23</b>
<b>8 REBATE FORMS.....</b>	<b>25</b>
8.1 Background to Renewable Energy Certificates.....	25
8.2 How RECs are calculated.....	25
8.3 Value of RECs.....	25
8.4 Renewable Energy Xchange terms and conditions .....	25
8.5 How to fill in the RECs form .....	26

8.6	Payment .....	27
<b>9</b>	<b>DISCLAIMER .....</b>	<b>28</b>
	<b>APPENDIX A. INSTALLATION REPORT FORM .....</b>	<b>29</b>
	<b>APPENDIX B. RENEWABLE ENERGY CERTIFICATES (RECS) INFORMATION SHEET</b>	<b>35</b>

**List of Tables**

Table 1	Collector Gross Weight & Dimensions (Filled) .....	10
Table 2	Delivery / recovery rates for Hills Solar tanks.....	13
Table 3	Water characteristics.....	21
Table 4	Warranty Coverage Details.....	22

**List of Figures**

Figure 1	Cylindrical collection method.....	6
Figure 2	Hills Solar tube collector cross section.....	6
Figure 3	Hills Solar tube collector .....	15
Figure 4	Manifold tube housing.....	16
Figure 5	Tube locking cap.....	16
Figure 6	Hills Solar tube collector cross section.....	23
Figure 7	Collector orientation .....	24

## **1 INTRODUCTION**

This manual details the owner's instructions for the Hills Solar evacuated tube hot water system.

If you are unsure of any information contained within this manual contact your Hills Solar dealer. For technical support ring: 1300 363 386.

### **1.1 Important forms you need to complete**

There are three important forms we need you to complete at the end of this manual and mail or fax to the addresses contained on the forms:

- Renewable Energy Certificate (RECs) Assignment form (used when replacing an existing electric system, installing in a new dwelling or replacing an old, existing electric boosted solar water heater).
- Installation Report Form – returned to Hills Solar to register your details for warranty purposes.
- Hills Solar Appraisal Form – returned to Hills Solar.

### **1.2 Document overview**

This manual contains the following sections:

Section 1—Introduction;

Section 2—Key Features and Benefits;

Section 3—Important Information;

Section 4—Owner Maintenance;

Section 5—Troubleshooting;

Section 6—Warranty;

Section 7—Frequently Asked Questions;

Section 8—Rebate Forms; and

Section 9—Disclaimer.

## 2 KEY FEATURES AND BENEFITS

The Hills Solar evacuated tubes are cylindrical; this means that they face the sun for longer, absorbing more of the sun's energy.

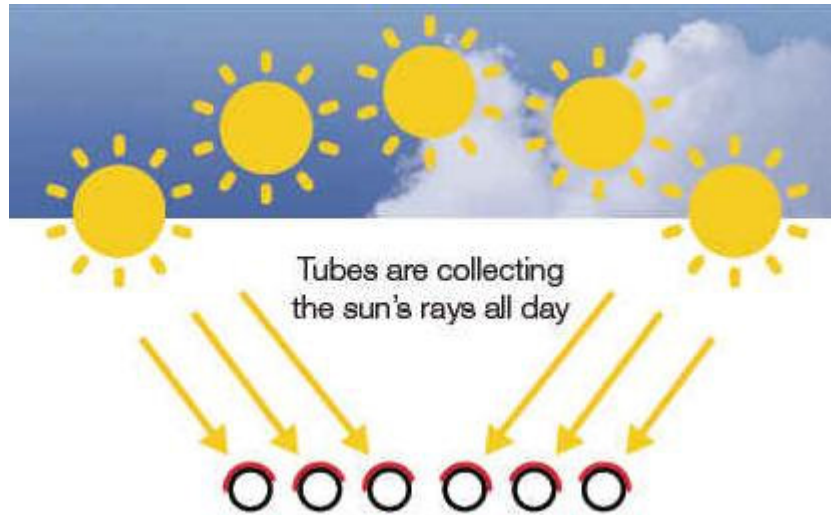

**Figure 1 Cylindrical collection method**

The tubes consist of 2 layers of borosilicate glass with a vacuum between these 2 layers. This evacuated layer in the tubes act much like a thermos flask retaining the energy absorbed from the sun. This helps increase the efficiency of the collector and also protects it from the effects of cold air. As a result, an evacuated tube solar collector is the perfect system for cooler climates.

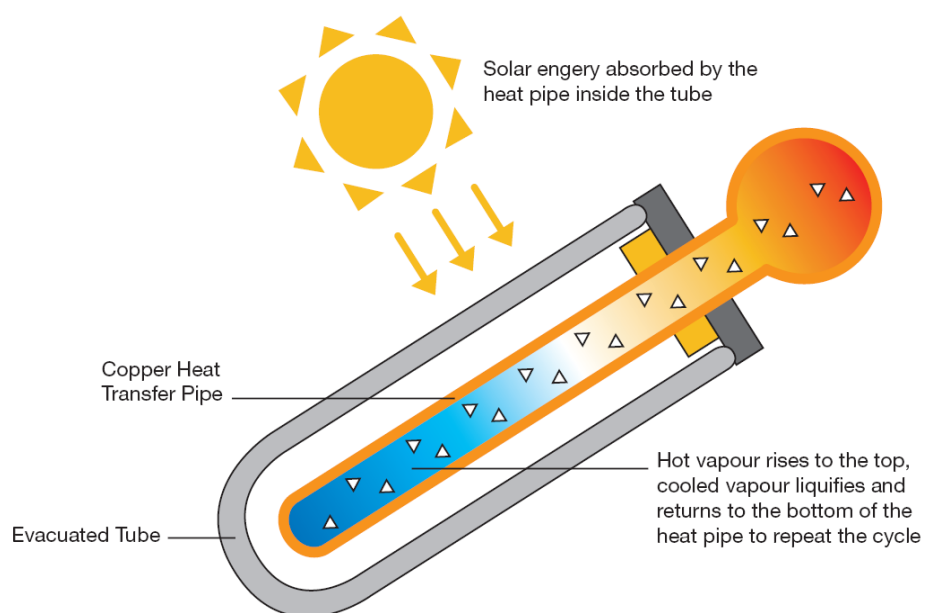

**Figure 2 Hills Solar tube collector cross section**

The sun's energy that is absorbed by the tubes is then transferred to your water via special heat pipes located inside each tube. A small amount of non-toxic liquid is inside each heat pipe. This liquid is turned to gas by the sun; this gas rises to the tips of the pipes, which are inserted, into a heat transfer manifold located on your roof. Water is then pumped through this manifold absorbing the heat and stored in a water storage tank located below.

The result is an incredibly efficient system to harness the heat from the sun even in extremely cold areas. Because the system is so efficient it does not require full sun and can work on cloudy or even rainy days.

Installing for optimum performance – In order for the collector to operate reliably at optimal efficiency, it must be correctly installed by a certified installer, who will ensure the installation follows the manufacturer's guidelines and meets all government and health regulations.

## 2.1 Key features

- Hills Solar evacuated glass tubes provide superior daily heat output due to the cylindrical absorber always being perpendicular to the sun.
- Insulation properties of the vacuum in the Hills Solar evacuated tube allow  $\geq 92\%$  of the heat from the sun to be retained.
- Heat is rapidly transferred from the copper heat pipe and header to the circulating water from the storage tank, passing through a well-insulated manifold, ensuring maximum solar heat gain.
- The Rockwool insulated collector manifold, sealed evacuated tubes and freeze-protected heat pipes allow reliable operation even in the coldest areas<sup>1</sup> and on cloudy or overcast days.
- Due to their cylindrical shape Hills Solar evacuated glass tubes are naturally self-cleaning when it rains and thus don't lose performance through the accumulation of dirt and pollutants.
- The internal copper manifold pipe in the Hills Solar collector is 35mm in diameter, ensuring greater water flow and is excellent for thermosiphon systems (systems with the tank on the roof with the collector using convection rather than a pump to circulate the hot water).
- For both gas and electric boosted systems, the Hills Solar collector uses advanced heat pipe technology to provide not only high solar conversion efficiency but also protection against freezing and leaking of any water through the evacuated glass tubes.
- The stainless steel collector frame provides both strength and long-term corrosion resistance.
- Easy installation and reliable operation is ensured through automated pump operation, low temperature protection and pre-wired power and sensor leads via the Hills Solar controller.
- Split system design with low profile collector removes the need for a large

---

<sup>1</sup> System plumbing must be well insulated and protected from freezing by use of the low temperature functionality of the Hills Solar Controller.

unsightly tank on the roof and the need for cranes, hoists or possible roof reinforcing.

## **2.2 Hills Solar storage tanks and boosting**

- Hills Solar use stainless steel storage tanks, which provide proven long-term corrosion resistance, without the need for a sacrificial anode.
- Polymeric outer casing with full Ultra Violet stabilisation on the Hills Solar storage tanks make them resistant to rust and protect them from the elements. This is particularly necessary in coastal, frost-prone, or damp areas.
- Hills Solar storage tanks incorporate a design to promote thermal stratification that prevents the mixing of incoming cold with hot water at the top of the tank.
- Dual Positive Domed Cylinder results in optimum water delivery and promotes flushing-through of suspended solids.
- In gas-boosted systems the Bosch Highflow Gas Booster heats water only when required, minimising energy wastage. The booster switches on when the temperature of the water from the storage tank is less than 60°C (the temperature that the solar transfer valve is set to).
- After power failures the Bosch gas booster does not require a technician to reset the gas booster.
- Storage tanks incorporate a high level of insulation to keep solar hot water hotter longer.



### **3 IMPORTANT INFORMATION**

#### **3.1 Australian/New Zealand Standards**

Installation must be completed in accordance with the requirements of AS/NZS 3500 and Australian Standard AS 5601 for installation of the Bosch Highflow Gas booster (in accordance with AG 601).

#### **3.2 Qualified installers**

Installation must be completed and checked off by a qualified plumbing professional.

#### **3.3 Water temperature**

Under AS/NZS3500 the temperature of the hot water being delivered from a solar system, either gas or electric boosted, is to be a maximum of 50°C; therefore, to comply with these standards, the water flowing from the Solar Tempering valve is to be set to a maximum of 50°C.

#### **3.4 Water flow**

Hot water flow from gas boosters is limited to either 21 or 26 litres per min (lpm) due to the flow rate of the gas booster - gas storage tanks might have delivered greater flow rates and customers might be used to that from their previous system.

It is advisable when using AAA-rated showerheads to use those with a minimum flow of 9 litres per minute. This is to ensure that Bosch units function efficiently. If you are experiencing changes in water temperature then this may be a result of using a showerhead that has a too low flow rate. It is also advisable to periodically check the showerhead to see if there is any build-up of material inside.

#### **3.5 Water quality**

In areas with “hard” water (>200ppm), lime scale may form inside the collector header pipe. In such regions, it is advisable to install a water-softening device to ensure the long-term efficient operation of the solar collector.

#### **3.6 Corrosion from bore water and chlorinated pools and spas**

Both copper & stainless steel are susceptible to corrosion when high concentrations of chloride are present; therefore, use of this system to heat chlorinated pool or spa water will void the Warranty. Chloride levels present in most reticulated public potable water supplies are safe for use in the solar collector provided there is no use of bore waters in the reticulated supply.

#### **3.7 Protection against freezing**

Freeze protection is incorporated into the Hills Solar controller with a low manifold temperature pump circulation feature. This feature turns the pump on if the manifold temperature drops to 3°C and turns off again when the temperature rises to 5°C. The design of the heat pipes inside the evacuated tubes provides natural protection against frost. This makes Hills Solar the natural choice in cold and frosty climates.

**Note:** In case of a power failure in frost-prone areas, the Hills Solar evacuated tubes are naturally frost-protected.

### 3.8 Collector gross weight and dimensions (filled)

The collector header pipe contained within the manifold has an OD (Outside Diameter) of 35mm and the water volume contained in the manifold is only minimal (see table below). The installed filled weights (including standard frame and tubes combined) and other relevant information are as follows:

**Table 1 Collector Gross Weight & Dimensions (Filled)**

Measurement	10 tube collector	22 tube collector	30 tube collector
<b>Weight (inc standard frame/tubes/manifold)</b>	40kg	82kg	108kg
<b>Height of collector (including manifold)</b>	2000mm	2000mm	2000mm
<b>Width of collector</b>	885mm	1845mm	2485mm
<b>Distance between inlet and outlet ports</b>	815mm	1775mm	2415mm
<b>Surface area of collector</b>	1.77m <sup>2</sup>	3.69m <sup>2</sup>	4.97m <sup>2</sup>
<b>Absorber area of collector</b>	0.80m <sup>2</sup>	1.76m <sup>2</sup>	2.40m <sup>2</sup>
<b>Aperture area of collector</b>	0.948m <sup>2</sup>	2.086m <sup>2</sup>	2.844m <sup>2</sup>
<b>Water that manifold in collector holds</b>	560ml	1260ml	1770ml
<b>Weight of low pitched roof frame</b>	6.0kg	10.5kg	11.1kg
<b>Weight of A-frame (for flat roofs)</b>	7.5kg	11.5kg	12.1kg

### 3.9 Stagnation and excess heat

Stagnation refers to the condition that occurs when the pump stops running due to either voltage reduction (brown out), power blackout or pump failure. A safety feature for this is the Pressure Temperature Relief (PTR) valve on the storage tank safely releasing high temperature water and/or steam from the system should the tank reach 95°C. The Automatic Air Vent on the manifold also releases steam from the system. There is a tank high temperature protection feature built into the Hills Solar Controller, which turns the pump off should the required maximum tank temperature be reached. This mechanism protects the system from overheating when hot water is not used for several days (e.g. when on holiday or during long periods of sunlight).

**Note:** The Automatic Air Vent on the collector prevents any air from entering the system (such as when there is a power failure) which can cause the pump to cavitate due to trapped air in the pump - stopping water circulating around the solar loop from the tank to the collector and back.

**Tip:** If you feel that your hot water usage is such that you don't require the extra performance that the Hills Solar collectors provide, such as when there is only 1 or 2 people using the system, you can remove a few of the heat pipes from the evacuated glass tubes and then replace just the tubes in the manifold. This will lower the collector output while not detracting from the aesthetics of the collector. This allows you to tailor each collector to perform to your particular requirements. Please call your Hills Solar dealer for more details.

### **3.10 Hail-prone areas**

Hills Solar evacuated tubes are surprisingly strong and able to handle significant impact stresses once installed. Testing and impact stress modeling shows that the Hills Solar evacuated tubes are able to withstand impact from hail up to 25mm (1") in diameter. The ability of the Hills Solar evacuated tubes to withstand impact from hail is greatly influenced by the angle of impact.

In the unlikely event that a tube is broken it can be replaced by following the procedure in Section 4.3 of this document. The Hills Solar collector can still function properly with one or more broken tubes and will not leak water as no water ever enters the evacuated tubes. A small reduction in heat output will result from broken tubes but will only be minimal (dependant on how many tubes are broken).

#### **3.10.1 Hills Solar controller settings**

The Turn-On and Turn-Off differential settings of the Hills Solar controller are designed to ensure optimum pump cycling as the evacuated tubes are heating. When the collector is 9°C hotter than the tank then the controller turns the solar pump on and turns it off again when the difference decreases to 5°C. Another feature built into the controller is a Maximum Tank Temperature feature which turns the pump off when the tank reaches 73°C, protecting against overheating of the storage tank.

**Note:** In the unlikely event that you need to move the tank or drain the tank during the day then you will need to either cover the collector or remove the collector sensor on the roof to avoid overheating the collector sensor.

### **3.11 Mounting frame**

#### **3.11.1 Frame material**

All frame components are made of 1.5mm thick 304-2B stainless steel making the frame both strong and corrosion resistant. It is important that frame attachment points and fasteners are also of suitable structural strength and corrosion resistance.

#### **3.11.2 Galvanic reaction between stainless steel and zinc galvanised steel**

Zinc or Zn/Al galvanized components should NOT be installed in direct contact with stainless steel, as galvanic reaction between the two metals can cause premature corrosion of the zinc coating and the steel underneath.

### 3.11.3 System operation

Solar radiation is greatest between 9am and 3pm and on clear sunny days. The Hills Solar controller will monitor the temperature of the water in the Hills Solar collector, returning it to the stainless steel storage cylinder once the temperature rises by a set amount of 9°C above the storage tank. The Controller then turns off the pump when there is only a 5°C difference between the collector temperature and storage tank temperature.

**Note:** The Hills Solar collector can remain quite hot even when the sun has disappeared, retaining enough heat to continue heating water. The pump can therefore still be going up to an hour or so after the sun has gone down.

#### Safe tray

The National Plumbing Code AS 3500.4 requires safe trays to be installed to all water heaters where, if there is a leak, property may be damaged. Installation of such trays must comply with Clause 4.4 and Sub clauses 1 to 5 of the Code.

#### Gas boosted systems

The Hills Solar Storage Tank is highly insulated to a level exceeding the required MEPS specification, thus minimising heat loss from the tank throughout both day and night. The cylinder is a storage vessel for the solar heated water. When solar gain is high the water may be of suitable temperature for direct use. During such periods the Bosch Highflow Gas booster is automatically OFF, with no standby or pilot heating losses. For periods when solar contribution is insufficient to reach required temperatures, or as the tank temperature drops due to hot water usage, the Bosch Highflow Gas booster will automatically boost the water temperature to the required level.

#### Points to note:

1. The gas booster operates when there is a minimum of 3L of hot water flowing. The use of water saving tap fittings that have less than 7.5L/min flow rate or that have restrictors in them can interfere with the operation. To check operation, open the hot tap fully to see if the gas booster comes on.
2. The electronic range of Bosch gas boosters (21E/26E) need a minimum of 150kPa water pressure (15.3m head pressure) in order to function properly. If the pressure is less than 150kPa then a water pressure pump can be installed (9.789kPa = 1m of head pressure).
3. When upgrading from a gas storage tank to a gas-solar system using an instantaneous gas booster check that the gas regulator has been upgraded from 1.375kPa to 2.75kPa otherwise you might experience low water pressure and/or water that does not get heated by the gas booster to the required temperature. Your plumber needs to obtain a replacement upgrade gas regulator through your local gas provider. Also, as a matter of precaution, replace the two rubber washers if the old ones look worn. If you turn on the gas booster at the power point before water is flowing through the unit it will go into default mode and allow no more than 40°C temperature to flow. To reset the gas booster turn it off at the power point for 1 minute and then turn back on. Leave another 1 minute before turning the water on again.

4. It is not recommended to use Electronic Temperature Controllers with continuous flow gas boosted solar systems, as their operation is limited due to the stored solar hot water often being hotter than the temperature selected.

### Electric boosted systems

The Hills Solar electric boosted water heater cylinder is fitted standard with a 3.6kW booster element, which is actuated via the preferred option of Off-Peak Tariff. This ensures that if water has not been fully heated by solar radiation during the day then it is heated overnight but only by the difference between the tank temperature through solar heating and the thermostat set temperature on the tank. The two heating periods are complimentary. If the tank is at a sufficient temperature through solar heating then the electric booster element doesn't come on. If Off-Peak Tariff is not available then the other option is to have Continuous Tariff with a Timer Switch installed which allows you to set when the booster comes on. You will generally require it to be set to come on in the night to allow the Hills Solar collectors to heat during the day and take advantage of reduced tariff electricity if available from your electricity provider.

**Table 2 Delivery / recovery rates for Hills Solar tanks**

Delivery/Recovery rates	Gas Boosted			Electric Boosted	
	250L – 21E	315L - 21E	315L – 26E	250L	315L
Available first Hours delivery – LITRES	873	936	1089	330	395
Hot water recovery for 50°C rise - LITRES	609	609	762	80	80

## 4 OWNER MAINTENANCE

Maintenance of the system includes the cleaning of material such as leaves from around the tubes and the possible replacement of broken tubes.

**Note:** It is recommended that protective gloves be worn when performing maintenance on the system.

### 4.1 Cleaning

Regular rain should keep the evacuated tubes clean, but if particularly dirty they may be washed with a soft cloth and warm, soapy water or glass cleaning solution.

### 4.2 Leaves

Leaves may accumulate between or beneath the tubes. Please remove these leaves regularly to ensure optimal performance and prevent potential fire hazards.

**Note:** The solar collector will not cause the ignition of flammable materials

### 4.3 Broken tube replacement

If a tube is broken it should be replaced as soon as possible to maintain maximum collector performance. The system will still operate normally even with a tube broken. Any broken glass should be cleared away to prevent injury.

#### **To remove and replace a tube:**

1. Open the locking cap at the base of the solar tube, slide the existing tube out and remove any glass pieces from the glass collector.
2. When removing the tube, the rubber ring in the manifold casing may pop out. If this occurs, replace this ring prior to inserting the new tube.

**Note:** Avoid skin contact with the Rockwool insulation, as skin irritation can occur.

#### **Unpacking the new tube:**

The heat pipes are pre-inserted into the evacuated tubes.

1. Remove the replacement tube from the box or shipping container.
2. Check that the heat pipe is snugly inserted into the evacuated tube and the top of the heat pipe is straight.
3. Check that the protective end cap is on the base of the evacuated tube and that the evacuated tube is silver at the bottom showing that the vacuum is good.

**Note:** Do not use the evacuated tube if there is a presence of a white colour at the bottom of the tube as this represents the absence of a vacuum in the tube.

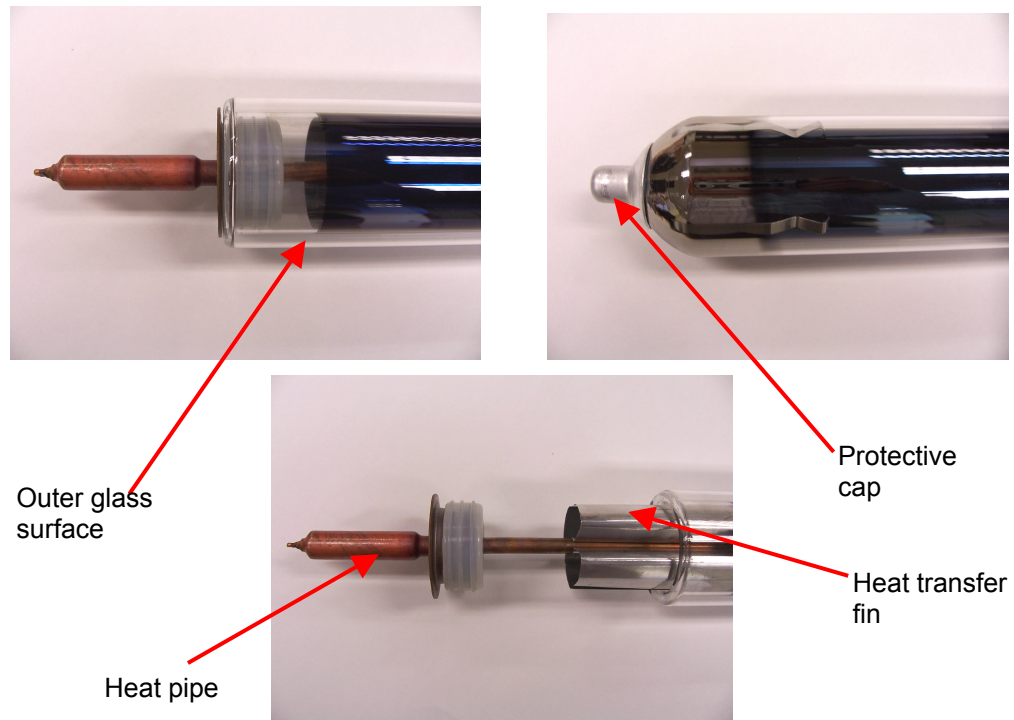

**Figure 3 Hills Solar tube collector**

#### 4.4 Evacuated tube heat pipe insertion

1. Lubricate the top outer surface of the evacuated tube with a small amount of water to allow it to slip through the manifold rubber ring seal.

**Note:** Do not allow any water to enter the evacuated tube.

2. Whilst firmly holding the evacuated tube at about mid length, guide the heat pipe tip in past the rubber seal and into the heat pipe port.
3. Using a slight left and right twisting action, push the evacuated tube up into the manifold.

The evacuated tube will push against the heat pipe condenser, pushing the heat pipe fully into the manifold port.

The heat pipe and evacuated tube are fully inserted once the black coating of the evacuated tube has disappeared up into the manifold (no clear glass visible) and the bottom of the tube sits correctly in the bottom locking cap. Figure 4 shows the manifold tube housing.



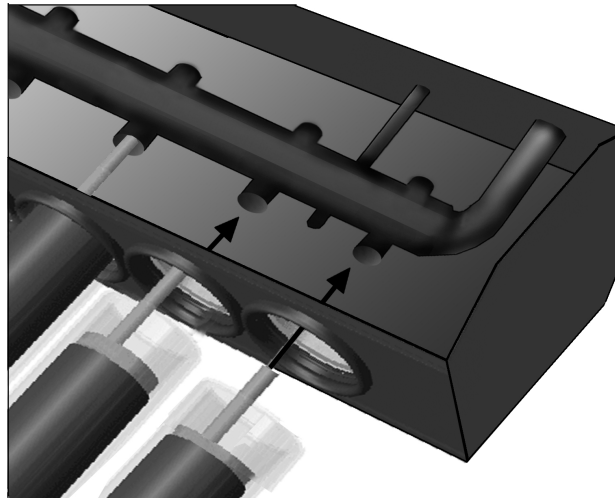

**Figure 4** Manifold tube housing

4. After the insertion of each tube, secure the tube in the locking cap by closing the locking cap and carefully tightening the screw located at the base of the locking cap until the tube is secure.

**Note:** Minimal pressure is required and care should be taken not to over tighten, as the screw only needs to be up against the protective cap on the base of the evacuated tube to stop it from moving.



**Figure 5** Tube locking cap

#### **4.5** Post installation cleaning

Post installation cleaning is limited to the cleaning of replacement tubes with a liquid glass cleaner and soft cloth. If this is not available, a sponge with clean water can be used.

#### **4.6** Insulation

The plumbing pipes running to and from the collector should be insulated. This insulation should be checked annually for damage. If available, UV stabilised foam (or metallic wrap) should be used, otherwise deterioration can occur over time.

**Note:** Up to 60% heat loss can occur if the insulation is non-existent or sub-standard.



#### **4.7 Other components**

Other parts of the system such as the pump and storage tank (electric or gas water heater) should be serviced/inspected by qualified technicians according to the manufacturer's own maintenance guidelines.

## 5 TROUBLESHOOTING

Only those inspection items listed in this section may be safely completed by the home owner. Any other system troubleshooting, system adjustments or repairs must be completed by a qualified tradesperson.

### 5.1 No Hot Water

If there is no hot water, it will generally be related to the gas or electric heating system, and not the solar tube collector. The solar tube collector pre-heats water, with final boosting completed by the electric element or gas booster system. Please contact your Hills Solar dealer.

If the gas booster is not turned on before sending water through it then it will default to 40°C. To reset the system turn the gas booster off via the power point or taking the plug out of the controller and wait two minutes before turning the system back on.

### 5.2 Reduced Solar Contribution

Solar contribution to your heating is directly related to the amount of solar radiation and the volume of hot water used. During the winter months, and periods of rainy or overcast weather, the amount of energy produced by the solar collector will be reduced.

As a general rule, the solar collector will have been sized and positioned to provide the majority of your summer hot water needs. During the winter, due to increased cloud cover and reduced solar radiation levels, solar contribution may be lower.

If, given similar environmental conditions, you feel that the solar contribution (as indicated by energy savings) has considerably reduced; there may be a problem with your solar heating system. This may be due to an incorrectly configured or damaged Controller, pump malfunction or problem with the boosting system. In such cases please contact your Hills Solar dealer.

### 5.3 DIY Investigation

The home owner may safely investigate the following to try and rectify problems with their system:

- **Does the circulation pump appear to be operating?** In good sunny weather the circulation pump should come on as can be seen by the 'PUMP' light on the Controller. The pump may run very quietly, and so you may need to touch the pump to feel for motor operation (slight vibration). The Controller has an orange light to indicate the pump has power going to it.
- **Are all the tubes intact?** If a tube has been damaged or broken it will reduce the system's overall performance only marginally and will need to be replaced as soon as possible. If a tube is damaged, follow the procedure.

**Note:** No water will escape from the manifold due to a broken evacuated tube, as the tubes do not have any water entering them.

- **Are there any apparent leaks in the plumbing to and from the collector?**  
Have the plumber tighten fittings where necessary.

## 5.4 Regular Releasing of Hot Water

If during normal daily hot water use, the Pressure Temperature Relief (PTR) valve on the tank is regularly releasing hot water, it indicates there may be a problem. A few litres a day is normal.

**Possible Causes:** The system may be producing more hot water than is required. This will be most apparent in the summer months, when solar radiation levels are high.

**Solution:** Remove some of the heat pipes from the evacuated tubes and replace in the manifold.

**Possible Causes:** A problem exists with the electric heating thermostat (Electric boosting only).

**Solution:** Contact your local Hills Solar dealer.

**Possible Causes:** A faulty PTR valve on the tank.

**Solution:** Contact your local Hills Solar dealer.

**Note:** If the PTR valve is less than one year old then it is covered under warranty.

**To test the system:** Run the hot water tap in the bathroom or kitchen for 5 minutes to release some heat from the system (the water will be hot, so be careful). If after this period, the tank is still regularly releasing hot water it indicates a definite problem. Please contact your Hills Solar dealer.

## 5.5 Safety Precautions

For any problems that involve plumbing or electrical connections the services of a qualified professional must be employed.

## 6 WARRANTY

**PLEASE ENSURE YOU AND YOUR INSTALLER COMPLETE, SIGN AND RETURN TO HILLS SOLAR THE INSTALLATION REPORT FORM (APPENDIX N) TO REGISTER YOUR WARRANTY**

### 6.1 Warranty Conditions

A licensed gasfitter/plumber and/or electrician in accordance with all installation instructions and all relevant statutory and local requirements of the State in which the system is installed must install the system.

This warranty only applies to the solar system/gas water heater/electric water heater product and does not apply to any additional electrical and/or plumbing parts supplied by the installer or the installation.

The system is covered for the indicated period from the date of the original purchase. Should a part of the complete solar system/water heater product be replaced during this period, only the balance of the original warranty will continue to remain effective.

The system is installed in a domestic household with the pump and controller connected to a 240V power supply at all times throughout the year.

Should this system be installed in a regional location where regular flushing is required due to sediment build-up, the drain cock for flushing must be fitted at the time of installation. If in doubt consult your Installer/Plumber.

Component manufacturers are at liberty to alter the design or construction for the products notwithstanding that the product may have been sold by description or sample, even though alterations made have been introduced from the date of Contract and the date of delivery provided that the products are of the same or similar quality and are fit for the purposes for which they are purchased. Such alterations shall not constitute a defect in design or construction under this Warranty.

The Warranty shall be limited to the replacement or repair, at the option of Hills Solar of any defective products and of such parts as have been damaged in consequence of the defect. Hills Solar is excluded to the extent allowable by Law from responsibility for any consequential loss including:

- Injury to persons;
- Damage to property;
- Economic loss;
- Pain and suffering; and
- Any legal or other damages flowing from any manufacturing fault/defect.

Hills Solar shall be under no obligation to return parts replaced at its option pursuant to this Warranty.

## 6.2 Warranty Exclusions

**THE FOLLOWING EXCLUSIONS SHALL CAUSE THE SYSTEM WARRANTY TO BECOME VOID. THIS MAY INCUR A SERVICE CHARGE AND COSTS FOR PARTS SHOULD THEY BE NECESSARY.**

Where service is required to reconnect the water heater operation due to problems related with abnormal water supply (i.e. high water pressure), faulty gas fitting, plumbing and/or electrical wiring, or major variations in gas or electrical energy supply.

If the system is sold, repaired or altered by any third party without the consent of Hills Solar.

Claims for damage to walls foundations (outside), furnishings (inside), roofs or other losses, directly or indirectly due to leakage from the water heater.

Where the system has been drained for a period without the solar tube collector being covered, resulting in damage to collector.

Accidental breakage is not covered by this warranty, and should be added separately to your general household insurance policy.

This warranty does not cover the effects of sludge/sediment as a result of connection to a water supply from unfiltered sources i.e. spring, dam, bore, river or other.

This warranty does not cover the effects of the connection of the appliance to bore waters and highly mineralized waters.

Where water stored in the cylinder exceeds the following levels:

**Table 3 Water characteristics**

Water Characteristic	Level
Total dissolved solids	600 mg/litre or p.p.m.
Total hardness	200 mg/litre or p.p.m.
Chloride	250 mg/litre or p.p.m.
Sodium	150 mg/litre or p.p.m.
Magnesium	10 mg/litre or p.p.m.
pH Levels	6.5 – 8.5
Electrical Conductivity	850 uS/cm

To the extent permitted by law the liability of Hills Industries Limited for breach of this Warranty, or for breach of any condition or warranty imposed by the Trade Practices Act, shall be limited in accordance with the terms of this Warranty to the replacement or repair, at the option of Hills Industries Limited, of any defective products or such parts as have been damaged as a consequence of the defect.

**Table 4 Warranty Coverage Details**

Coverage Details	Coverage Period
Replacement of major components, including Gas Heater, Evacuated Tube Solar Collector, Stainless Steel Storage Cylinder, Solar Circulating Pump, Electric Tank Heating Element, Electric Tank Thermostat that fail due to faulty manufacturing or workmanship will be provided at no charge to the customer for the replacement parts/components. The period for which free replacement applies varies for different components and the details appear below. Replacement or repair excludes all transport costs.	
Hills Solar Controller.	One year – Labour one year.
Flow Control Valve.	Three years – Labour one year.
Salmson Circulating Pump, including associated plumbing parts.	One year – Labour one year.
Bosch Highflow Gas Booster Burner. Including parts and labour.	Three years.
Replacement of Hills Solar Evacuated Tube Solar Collector and Manifold.	Ten years – Labour one year.
Replacement of minor components in the Everlast storage tank.	One Year – Labour one year.
Replacement of Everlast stainless steel storage cylinder in the event of the cylinder rupturing	Ten Years – Labour one year.
Bosch Highflow Gas Booster Heat Exchanger.	Ten years. – Labour one year.
Replacement of Mounting Frame and Copper Header.	Ten Years – Labour one year.
Other parts.	One year – Labour one year.

Both copper & stainless steel are susceptible to corrosion when high concentrations of chloride are present, and therefore use of this system to heat chlorinated pool or spa water will void the Warranty. Chloride levels present in most reticulated public potable water supply are safe for use in the solar collector provided there is no use of bore waters in the reticulated supply.

Where the Solar System is installed outside the boundaries of a Capital Cities Metropolitan area i.e. those areas on STD, the cost of transport, insurance and traveling will be charged to the owner.

## FREQUENTLY ASKED QUESTIONS

### Why Choose a Hills Evacuated Tube Solar Hot Water System?

Evacuated tube technology has been used in Europe for many years and is more efficient in cooler climates than standard flat plate technology. At Hills we have undertaken research to choose a quality system that will perform best in all conditions especially in winter when thermal energy is at its lowest therefore giving you the best performance possible all year.

### How does an Evacuated Solar Tube Work?

The advanced design incorporates tubes that consist of 2 layers of borosilicate glass with a vacuum layer between them. The Vacuum acts like a thermos flask, retaining up to 97% of the thermal energy, resulting in an increased efficiency. The Sun's thermal energy is then transferred to the manifold via the heat pipe located in each tube.

The small amount of evaporative liquid in each tube is super heated by the sun's energy and forms into a gas. The gas rises to the top of each pipe. Heat transfer then occurs between the pipe and water passing through the manifold. The water is then transferred to the tank.

The cylindrical design of the tubes ensures effective collection of the sun's thermal energy throughout the day.

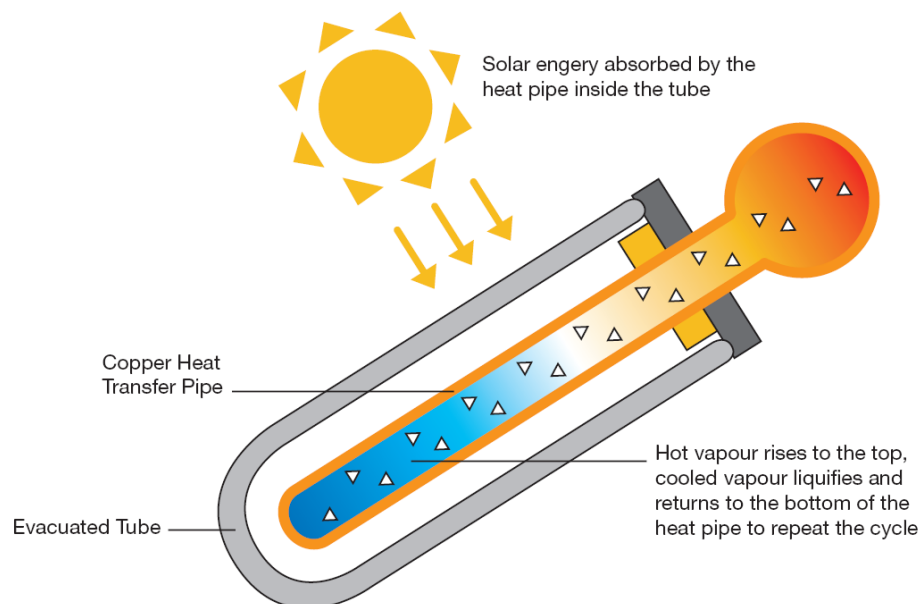

**Figure 6 Hills Solar tube collector cross section**

### Will my system work if the sun doesn't shine?

Even on cloudy and rainy days you may still achieve some solar gain. The Hills Solar system is available with an electric or gas booster to assist heating the water on poor solar gain days.

### **Are the Hills Solar Systems eligible for Government rebates?**

Provided you meet the Federal Governments criteria all Hills Solar Systems are eligible for RECs (Renewable Energy Certificates). There is also a \$1,000.00 Federal Government rebate. For more information visit <http://www.orer.gov.au/> (Office of the Renewable Energy Regulator) Some States and local councils also offer incentives on installation of solar hot water systems.

### **What are RECs?**

RECs are a form of currency created by the Federal Government under the Renewable

Energy (Electricity) Act 2000 and are used to demonstrate compliance with the requirements of the Government's Mandatory Renewable Energy Target (MRET) scheme. The Hills Solar System qualifies for these generous Government Rebates (conditions apply). There are 4 Australian zones, which will determine the amount of RECs per system. Please visit the Hills Solar Web Site at <http://www.hillsolar.com.au> for the RECs zone for your postcode and click here to see the number of RECs certificates applicable for each Hills Solar product.

### **Which is the best collector orientation?**

The ideal location for collectors is facing due North, however 45 degrees North West or North East is acceptable with minimal effect due to the cylindrical design.

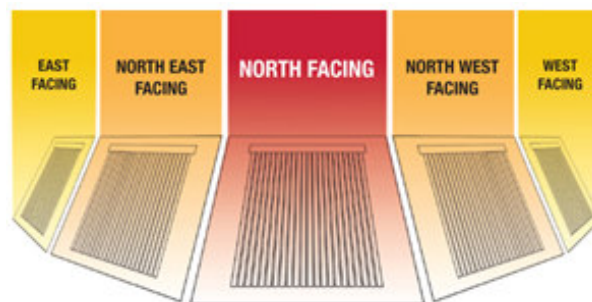

**Figure 7 Collector orientation**

### **Why do Hills use a stainless steel storage tank?**

Stainless steel tanks have a natural oxide barrier to corrosion, therefore eliminating the requirements of a sacrificial anode, which saves the cost or replacing approx every 5 years. Stainless steel tanks also have a longer life than standard Vitreous enamel tanks.

### **Can I fit a Hills Solar system to my existing hot water system?**

In most cases a Hills Solar system can be retro-fitted to an existing hot water tank. Please consult your local dealer for more information.

### **Where can I buy a Hills Solar Hot Water system?**

Please visit the Hills Solar Web Site at <http://www.hillsolar.com.au> to find your nearest dealer.



## **8 REBATE FORMS**

**Please read this information sheet before completing your Renewable Energy Certificate Assignment Form**

### **8.1 Background to Renewable Energy Certificates**

Renewable Energy Certificates (RECs) are a new form of currency created by the Federal Government under the Renewable Energy (Electricity) Act 2000 and are used to demonstrate compliance with the requirements of the Government's Mandatory Renewable Energy Target (MRET) scheme.

The Australian Government's MRET commenced in April 2001 and requires the sourcing of 9,500 gigawatt hours of extra renewable electricity per year by 2010 through to 2020. This target is enough power to meet the residential electricity requirements of approximately four million people.

MRET places a liability on wholesale purchasers of electricity to proportionately contribute towards the generation of the additional renewable energy. The target applies nationally, and is implemented through the Renewable Energy (Electricity) Act 2000. An independent panel reviewed the legislation underpinning the target.

The Renewable Energy (Electricity) Act 2000 establishes the rules for creating RECs. The Act states that the RECs must be in electronic form, that every certificate must have its own unique code and must be registered by the Office of Renewable Energy Regulator (ORER) before they are considered valid.

### **8.2 How RECs are calculated**

One REC is generated for every 1 MWh of renewable energy power. The range of Hills Solar water heating systems have been assessed by an independent testing authority to establish the performance and efficiency of each system in saving energy for water heating. These systems are then allocated a number of RECs reflecting how much energy they can save each year.

### **8.3 Value of RECs**

The value of a REC is determined by a market mechanism and is therefore subject to change over time, depending upon the size of the market (how many RECs can be bought) and the number of RECs certificates available to buy. Check with your Hills Solar dealer to see how many RECs your system is eligible for.

### **8.4 Renewable Energy Xchange terms and conditions**

A Hills Solar water heater is eligible to receive Renewable Energy Certificates if:

- Installing a Hills Solar system in a new dwelling
- Replacing a water heater with a Hills Solar system that has been in the same dwelling for more than 1 year. The original heating system could be electric, and if the original heating was gas, solar, or fuel, it is eligible for RECs if installed after 10 September 2006.
- Installing a Hills Solar system to replace an existing electric boosted solar hot

water system that has been in the same dwelling for at least 1 year

- Installing a Hills Solar system in an existing dwelling that has not had a hot water system already installed

I understand that RECs are currently not payable for a solar retro-fit of an existing gas or electric storage water heater.

Certificates may only be created once or assigned once during the life of the installation and they must be created with 12 months of the installation.

By signing this form, I assign the rights to create Renewable Energy Certificates for this installation to Renewable Energy Xchange (REX) for payment:

- To be received in equal value of the Renewable Energy Certificates created from the installation of a solar hot water system; or
- I have received a point of sale discount that is equal to the value of the Renewable Energy Certificates that will result from the installation of a solar hot water system.

I understand that falsely creating RECs is an offence, which can attract heavy penalties under the Renewable Energy (Electricity) Act 2000.

I understand that once an owner has assigned rights to create RECs, no other RECs can be created or assigned with respect to that solar water heater installation.

I understand that any payment made is inclusive of GST and is for the assignment of my rights. Where I am registered for GST I will provide REX with a tax invoice for the assignment of my rights which will be for the value of the RECs traded less the service fee as advised at the time of sale by REX.

I agree that in the event my RECs assignment is invalid or if Renewable Energy Xchange cannot create or register the RECs that I will not be entitled to any payment.

I agree to reimburse Renewable Energy Xchange the full amount if payment has already been received by me.

I agree that the Office of the Renewable Energy Regulator or its appointed agent can inspect my system within the first 5 years of operation.

I understand that the information on this form will be made available to Renewable Energy Xchange, Hills Industries Limited and ORER. Unless consent is granted by me, will not be used for any other purpose other than to create, check or Audit Renewable Energy Certificates.

I have checked that detail entered on this form and the installation report is correct.

## **8.5 How to fill in the RECs form**

Please fill out all the areas relevant to your installation, ensure that you and your installer have signed the bottom of the RECs Assignment Form contained in this document. Return to Renewable Energy Exchange, details are at the bottom of the form. Please check that the details are correct as missing or incorrect information may invalidate your right for payment.

## **8.6 Payment**

Ask your dealer how many RECs your system creates or call Renewable Energy Xchange on 1300 738 318. Simply fill in the RECs Assignment Form on the next page and send it back to Renewable Energy Xchange. Renewable Energy Xchange will then get your certificates registered and provide you with a once off payment less our administration fee to the value of your RECs or you are free to register and create your own RECs or assign them to whomever you wish, visit [www.orer.gov.au](http://www.orer.gov.au) for further information.

## 9            **DISCLAIMER**

This manual contains an overview of the Hills Solar hot water system and all instructions/recommendations must be followed exactly as stated herein. Hills Industries Limited is not responsible for any loss or damage to any person or property of any type, whether direct or consequential, arising from the operation of the solar hot water system or any of its components.

OH&S Disclaimer – Hills Industries Limited and its dealer work with and recommend various installation and plumbing companies to install, test and certify correct operation of solar hot water systems. Hills Industries Limited is a supplier of systems only. Each installation must be covered by the installer's insurances, commercial terms and conditions and by the applicable OH&S legislation.

Each person that installs assembles or services must comply with all OH&S requirements relevant to the type of work being conducted including, but not limited to, plumbing work, work on roofs and electrical work. Hills Industries Limited and its dealers do not accept any responsibility for any loss or damage to any person or property of any type, whether direct or consequential, arising from the installation, maintenance, or operation of the solar hot water system or any of its components.

**APPENDIX A. INSTALLATION REPORT FORM**

**Installation report form (page 1 of 3)**

After the completion of installation, the following form must be completed by the installer and faxed to Hills Solar within 5 working days of installation date.

**PLEASE WRITE CLEARLY**

Customer Name: _____ Installation address: _____ _____ _____ Phone No: (Work) _____ (Home) _____ (Mobile) _____ Fax number: _____ Email Address: _____ Invoice Number: _____
---

Installer Name: _____ Installer License Number: _____ Installation Date: _____ Company name: _____ Company address: _____ _____ _____ Installer Phone No: _____ (Mobile) _____ Fax number: _____
--

Hills Solar Collector Serial Number(s) on the back of the collector: \_\_\_\_\_

(If gas Boosted) Bosch Highflow Gas booster Serial Number: \_\_\_\_\_

(If electric boosted) Hills Solar Storage Tank Serial Number: \_\_\_\_\_

(If gas boosted) Hills Solar Storage Tank Serial Number: \_\_\_\_\_



**This page is blank intentionally to facilitate faxing**

<b>Installation report form (page 2 of 3)</b>	<b>Please tick applicable</b>	
	<b>YES</b>	<b>NO</b>
1. Collector faces due North. If not facing North what is the aspect the collector is facing .....Estimated pitch of roof ..... °deg.		
2. Collector is installed at an appropriate angle of above 20°deg.		
3. Manifold is not significantly shaded throughout the day.		
4. Manifold is not likely to be struck by falling objects such as branches or falling fruit.		
5. Frame is secured to structurally sound roof framing or to side of building.		
6. Pressure limiting valve has been installed.		
7. All plumbing valves have been checked to be open to allow water flow.		
8. Solar flow and return lines are 15mm copper (no plastic olives used) and plumbing is leak-free.		
9. Plumbing pipe runs are well insulated.		
10. System is fitted with PTR Valve on the tank outlet and an Air Vent on the collector and the collector air vent has been backed of one complete turn.		
11. PTRV on the tank will dump only onto high temperature resistant material or into nearby drain and will not pose a danger of scolding people.		
12. Insulation around the piping above roof level is protected with UV foil wrap.		
13. Thermal paste has been applied to heat pipes and sensor probes before insertion and silicon has been applied around the sensor well on the collector to protect against water entry.		
14. Functional checks for the Hills Solar Controller have been carried out.		
15. Electric booster element has been wired up and <b>not</b> connected to the Aux out on the Controller.		
16. Pump, controller, sensor probes and all electrical connections are protected from water entry.		
17. Pump has been checked for operation by feeling the solar return line (copper piping) for heat and system has been bled. Sensor Emulator can be used if there is no sun to trigger the pump.		
18. Flow Control Valve has been installed directly after pump and correct flow rate set.		
19. Evacuated tubes have been cleaned to remove any thermal paste or other marks on them.		
20. Orange cap tempering valve has been installed.		
21. Check gas delivery (for Hills Solar gas boosted systems).		
22. Check 60°C bridge has been inserted into the Bosch gas booster (for gas/solar only).		
23. Water quality has been checked.		
24. Warranty document supplied to customer and the basic operation of the system explained.		



**This page is blank intentionally to facilitate faxing**



**Installation Report Form continued (page 3 of 3)**

<b>Checklist for controller/pump function</b>			
<b>Sensor Lights</b>	<b>Normal condition</b>	<b>Fault condition</b>	<b>Check item</b>
Green power light	ON	OFF	Check power supply
Orange pump light	ON & OFF Cycling	ON constant or OFF constant	Check sensors Check power at pump
Blue pump pipe sensor	OFF	Flashing	Check sensor and wire for damage
Red collector sensor	OFF	Flashing	Check sensor and wire for damage
Sensor lights 3 & 4	OFF	Both flashing	Turn off power & restart

This checklist is a guide only. Installers may add or remove items as required. It is suggested that a copy of the checklist be provided to the end user along with a warranty document upon completion of the system installation.

**Please Write Clearly**

**Home Owner's Name (printed)**

**Installer's Name (printed)**

\_\_\_\_\_

**Home Owner Signature**

\_\_\_\_\_

**Installer Signature**

\_\_\_\_\_

**Date signed**

\_\_\_\_\_

**Date signed**

\_\_\_\_\_

\_\_\_\_\_

**Where did you purchase your Hills Solar hot water system?**

Retailer:

\_\_\_\_\_

Retailer Address:

\_\_\_\_\_

Suburb: \_\_\_\_\_ Postcode: \_\_\_\_\_ State: \_\_\_\_\_

Date of purchase: \_\_\_\_\_

**Please fax this Installation Report Form to Hills Solar on 08 8301 3166 within 5 working days of installation date. Alternatively it can be posted using the pre-paid envelope supplied.**



**This page is blank intentionally to facilitate faxing**

## **APPENDIX B. RENEWABLE ENERGY CERTIFICATES (RECS) INFORMATION SHEET**

**Please read this information sheet before completing your RECs Assignment Form**

### **Background to Renewable Energy Certificates**

Renewable Energy Certificates (RECs) are a new form of currency created by the Federal Government under the Renewable Energy (Electricity) Act 2000 and are used to demonstrate compliance with the requirements of the Government's mandatory renewable energy target (MRET) scheme.

The Australian Government's MRET, which commenced in April 2001, requires the sourcing of 9,500 gigawatt hours of extra renewable electricity per year by 2010 through to 2020 – which is enough power to meet the residential electricity needs of four million people.

MRET places a liability on wholesale purchasers of electricity to proportionately contribute towards the generation of the additional renewable energy. The target applies nationally, and is implemented through the Renewable Energy (Electricity) Act 2000. The legislation underpinning the target was reviewed by an independent panel and the report provided to the Government in September 2003.

The Renewable Energy (Electricity) Act 2000 establishes the rules for creating RECs. The Act states that the RECs must be in electronic form, that every certificate must have its own unique code and that the RECs must be registered by the Renewable Energy Regulator before they are considered valid.

### **How RECs are calculated?**

One REC is generated for every 1 MWh of renewable energy power. The range of Endless Solar water heating systems have been assessed by an independent testing authority to establish the performance and efficiency of each system in saving energy for water heating. These systems are then deemed to create a number RECs reflecting how much energy they can save each year.

### **Value of RECs**

The value of a REC is determined by a market mechanism and is, therefore, subject to change over time depending upon the size of the market (how many RECs can be bought) and the number of RECs certificates available to buy. Check with your Hills Endless Solar distributor to see how many RECs your system is eligible for.

### **Renewable Energy Xchange Terms and conditions**

A Solar Hot Water heater is eligible to receive Renewable Energy Certificates if:

- Installing an ORER approved Solar Hot Water system in a new dwelling
- Replacing a water heater with an approved Solar Hot Water system that has been in the same dwelling for more than 1 year. The original heating system could be electric, and if the original heating was gas, solar, or fuel, it is eligible

for RECs if installed after 10 September 2006.

- Installing an approved Solar Hot Water system to replace an existing electric boosted solar hot water system that has been in the same dwelling for at least 1 year
- Installing an approved Solar Hot Water System in an existing dwelling that has not had a hot water system already installed
- I understand that RECs are currently not payable for a solar retro-fit of an existing gas or electric storage water heater.
- Certificates may only be created once or assigned once during the life of the installation and they must be created with 12 months of the installation.
- By signing this form, I assign the rights to create Renewable Energy Certificates for this installation to Renewable Energy Xchange (REX) for payment:
- To be received in equal value of the Renewable Energy Certificates created from the installation of a solar hot water system.
- or I have received a point of sale discount that is equal to the value of the Renewable Energy Certificates that will result from the installation of a solar hot water system.
- I understand that falsely creating RECs is an offence, which can attract heavy penalties under the Renewable Energy (Electricity) Act 2000.
- I understand that once an owner has assigned rights to create RECs, no other RECs can be created or assigned with respect to that solar water heater installation.
- I understand that any payment made is inclusive of GST and is for the assignment of my rights. Where I am registered for GST I will provide REX with a tax invoice for the assignment of my rights which will be for the value of the RECs traded less the service fee as advised at the time of sale by REX.
- I agree that in the event my RECs assignment is invalid or if Renewable Energy Xchange cannot create or register the RECs that I will not be entitled to any payment.
- I agree to reimburse Renewable Energy Xchange the full amount if payment has already been received by me.
- I agree that the Office of the Renewable Energy Regulator (ORER) or its appointed agent can inspect my system within the first 5 years of operation.
- I understand that the information on this form will be made available to Renewable Energy Xchange, Hills Industries Limited and the Australian Government for auditing or verification purposes. For example, information about the hot water system may be provided to the Australian Greenhouse Office for the purpose of verifying eligibility under the Solar Hot Water Rebate Programme in respect of this hot water system. Unless consent is granted by me will not be used for any other purpose other than to create, check or Audit Renewable Energy Certificates.
- In the instance where the installation is eligible for the Federal Solar Hot Water Rebate, the system location address, system details will be made available to the Australian Greenhouse Office for database matching when processing your application.

- I have checked that detail entered on this form and the installation report is correct.

### **How to fill in this form**

Please fill out all the areas relevant to your installation, ensure that you and your installer have signed the bottom of the RECs Assignment Form. Return to Renewable Energy Exchange, details are at the bottom of the form. Please check that the details are correct as missing or incorrect information may invalidate your right for payment.

### **Payment**

Ask your distributor how many RECs your system creates or call Renewable Energy Xchange on 1300 738 318. Simply fill in the RECs Assignment Form on the next page and send it back to Renewable Energy Xchange. Renewable Energy Xchange will then get your certificates registered and provide you with a once off payment less an administration fee to the value of your RECs or you are free to register and create your own RECs or assign them to whomever you wish visit [www.orer.gov.au](http://www.orer.gov.au) for further information.



**This page is blank intentionally to facilitate faxing**

Please read the Terms & Conditions before completing this Assignment form

<p><b>Owners Details (BLOCK LETTERS ONLY)</b></p> <p>First Name: _____ Surname: _____</p> <p>Postal Address: _____</p> <p>Suburb: _____ State: _____ Post Code: <table border="1" style="display: inline-table; border-collapse: collapse;"><tr><td style="width: 20px; height: 20px;"></td><td style="width: 20px; height: 20px;"></td><td style="width: 20px; height: 20px;"></td><td style="width: 20px; height: 20px;"></td></tr></table></p> <p>Telephone: (w) _____ (h) _____</p> <p>Mobile: _____</p> <p>Email: _____</p>					<p><b>Payment Preference</b></p> <p>I require payment via (please tick)</p> <p><input type="checkbox"/> Cheque (will be issued to the owners name)</p> <p>Or by</p> <p><input type="checkbox"/> Direct Deposit (complete the details below)</p> <p>Account Name: (BLOCK LETTERS ONLY)</p> <p>_____</p> <p>_____</p> <p>Bank: (BLOCK LETTERS ONLY)</p> <p>_____</p> <p>BSB:</p> <p>_____</p> <p>Account Number:</p> <p>_____</p> <p>Signature:</p> <p>_____</p>											
<p><b>Installation Details (BLOCK LETTERS ONLY)</b></p> <p>Installation Address: _____</p> <p>Suburb: _____ State: _____ Post Code: <table border="1" style="display: inline-table; border-collapse: collapse;"><tr><td style="width: 20px; height: 20px;"></td><td style="width: 20px; height: 20px;"></td><td style="width: 20px; height: 20px;"></td><td style="width: 20px; height: 20px;"></td></tr></table></p> <p>Brand: <b>Endless Solar</b> Model: _____ Tank Serial Number: _____ - _____</p> <p>Number of tubes: _____ Installation date: ____/____/____</p> <p><b>Solar Hot Water Installation</b> (please tick applicable)</p> <p>[ <input type="checkbox"/> ] New building [ <input type="checkbox"/> ] Replacing electric hot water [ <input type="checkbox"/> ] Replacing Solar water heater</p> <p>[ <input type="checkbox"/> ] First installation [ <input type="checkbox"/> ] Replace gas hot water (installed after 10/9/06) [ <input type="checkbox"/> ] Other (installed after 10/9/06)</p>					<p><b>GST Declaration</b></p> <p>I declare that (please tick appropriate box)</p> <p><input type="checkbox"/> I am not registered for GST</p> <p><input type="checkbox"/> I have issued to Renewable Energy Xchange a valid tax invoice for GST purposes</p>											
<p><b>Replacing old electric-boosted solar heater:</b> For systems installed before 11 September 2006, if an electric-boosted solar water heater was replaced, include the following details for the old solar water heater:</p> <p>Brand of old system: _____ System model: _____</p> <p>Serial number: _____ Size of tank (litres): _____</p> <p>Were any RECs claimed for this system? please tick one [ <input type="checkbox"/> ]Yes [ <input type="checkbox"/> ]No [ <input type="checkbox"/> ]Don't know</p> <p>How many RECs could have been created for this system?</p>	<p style="text-align: center;"><b>Office Use Only</b></p> <table border="1" style="width:100%; border-collapse: collapse;"> <tr> <td style="width: 20%;">SW</td> <td style="width: 80%;"></td> </tr> <tr> <td>R/Date</td> <td></td> </tr> <tr> <td>P/Date</td> <td></td> </tr> <tr> <td>Approval</td> <td></td> </tr> <tr> <td>Pyt/ref</td> <td></td> </tr> <tr> <td>PCHK</td> <td style="text-align: center;"> <table border="1" style="display: inline-table; border-collapse: collapse;"> <tr> <td style="width: 30%;">REC</td> <td style="width: 30%;">DBU</td> <td style="width: 30%;">PD</td> </tr> </table> </td> </tr> </table>	SW		R/Date		P/Date		Approval		Pyt/ref		PCHK	<table border="1" style="display: inline-table; border-collapse: collapse;"> <tr> <td style="width: 30%;">REC</td> <td style="width: 30%;">DBU</td> <td style="width: 30%;">PD</td> </tr> </table>	REC	DBU	PD
SW																
R/Date																
P/Date																
Approval																
Pyt/ref																
PCHK	<table border="1" style="display: inline-table; border-collapse: collapse;"> <tr> <td style="width: 30%;">REC</td> <td style="width: 30%;">DBU</td> <td style="width: 30%;">PD</td> </tr> </table>	REC	DBU	PD												
REC	DBU	PD														
<p><b>Installers Details (BLOCK LETTERS ONLY)</b></p> <p>First Name: _____ Surname: _____</p> <p>Company Name: _____</p> <p>Postal Address: _____</p> <p>Suburb: _____ State: _____ Post Code: <table border="1" style="display: inline-table; border-collapse: collapse;"><tr><td style="width: 20px; height: 20px;"></td><td style="width: 20px; height: 20px;"></td><td style="width: 20px; height: 20px;"></td><td style="width: 20px; height: 20px;"></td></tr></table></p> <p>Telephone: (w) _____ (h) _____</p> <p>Mobile: _____</p> <p>Email: _____</p> <p><input type="checkbox"/> Please tick here if you would like to be included in our installer contact list.</p>																

Continued over page

**Mandatory Declaration**

- I am the owner of the above installation and I agree to assign my right to create REC's to Renewable Energy Xchange.
- I have not previously assigned or created any REC's for this installation.
- I understand the Terms & Conditions included with this form.
- I hereby authorise Renewable Energy Xchange to amend errors & to clarify requirements under the Renewable Energy (Electricity) Act 2000.
- I understand that this system is eligible for \_\_\_\_\_ RECs and in exchange for assigning my right to create these RECs I will receive from Renewable Energy Xchange the monetary value of the sold certificates at the time of trade less an administrative processing fee.
- or I have received a point of sale discount and request payment of the RECs value be made to: \_\_\_\_\_
- The information given in this form is true and accurate to the best of my knowledge and I am aware that penalties can be applied for providing misleading information in this form under the Renewable Energy (Electricity) Act 2000.

**The Owner of the Installation**

**Witnessed by the Agent / Distributor / Installer**

Signed: \_\_\_\_\_  
 Name: \_\_\_\_\_  
 Date: \_\_\_\_\_

Signed: \_\_\_\_\_  
 Name: \_\_\_\_\_  
 Date: \_\_\_\_\_

**Privacy:** Renewable Energy Xchange will use and disclose personal information obtained for the primary purpose for which it was collected.

Please tick here if you do not wish to receive further product information from Renewable Energy Xchange & Hills Industries Limited and/or its related companies and distributors.

If at any time you wish to unsubscribe, please contact Renewable Energy Xchange.

Return this completed form to



**Renewable Energy Xchange**  
**PO Box 174**  
**Canterbury NSW 2193**

**Or FAX to:**  
**1300 738 317**

**Or Email to:** [Info@r-e-x.com.au](mailto:Info@r-e-x.com.au)

*Only a pdf file of the completed & signed assignment form is acceptable*

ABN: 85 308 716 397

For assistance in completing this form call 1300 738 318