

# NOT RECOMMENDED X

⊞ = Fuse/Breaker

R1 & R2 = Effective cable resistance

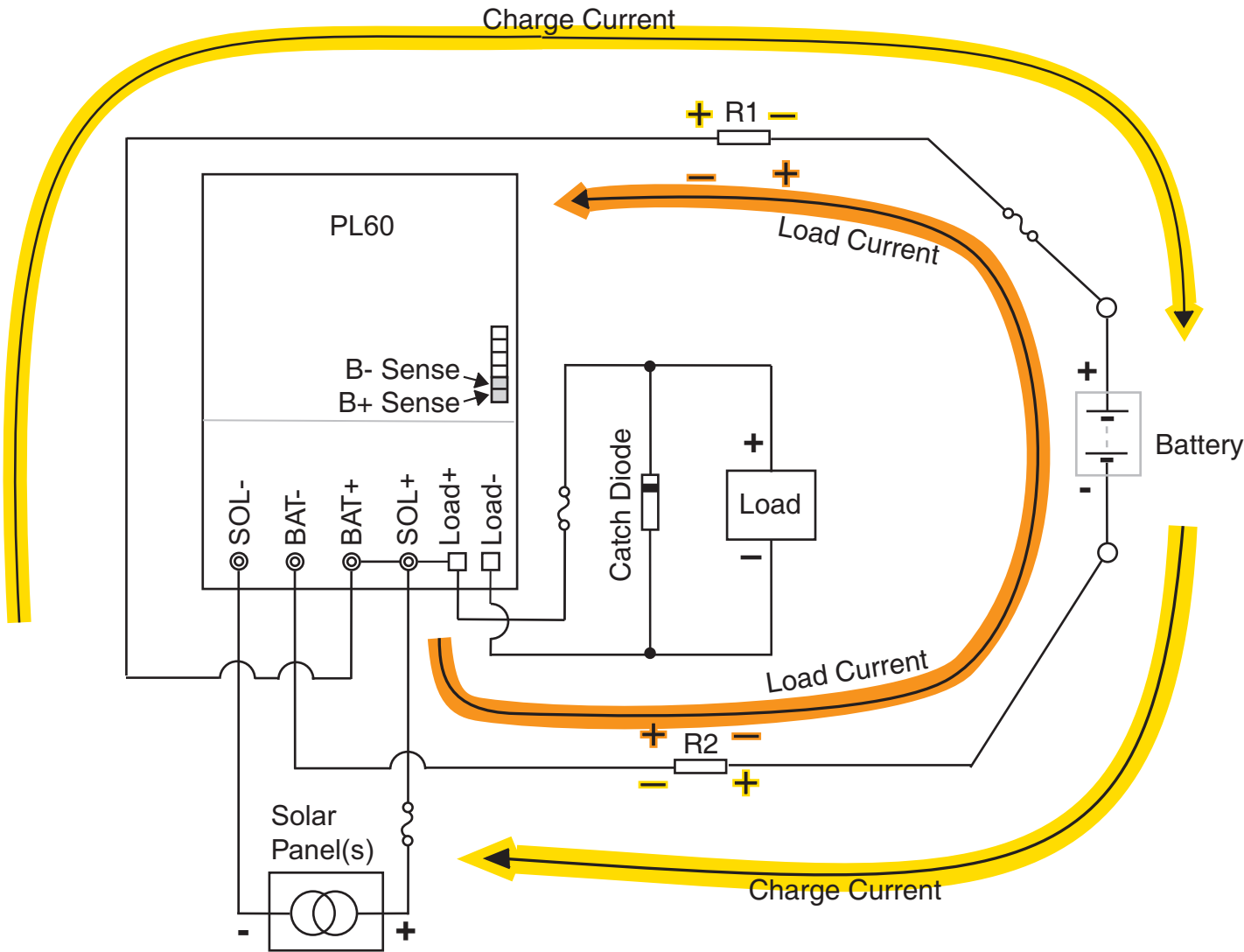

Charge current and Load current can cause a voltage drop on wires that the regulator uses to monitor battery voltage. Charge current will *increase* apparent battery voltage, and Load current will *decrease* apparent battery voltage read by the regulator.

PL60 Voltage Drop -> Non-Recommended Installation Layout

This diagram is for reference only. Wiring and fuses etc. must be installed as specified by the relevant Australian Standards.