

SunPower 215 Solar Panel

Exceptional efficiency and performance

The SunPower 215 Solar Panel provides industry leading efficiency and performance. Utilising 72 next generation SunPower all-back contact solar cells and an optimised panel design, the SunPower 215 delivers an unprecedented total panel conversion efficiency of 17.3%. The 215 panel's reduced voltage-temperature coefficient and exceptional low-light performance attributes provide far higher energy delivery per peak power than conventional panels.

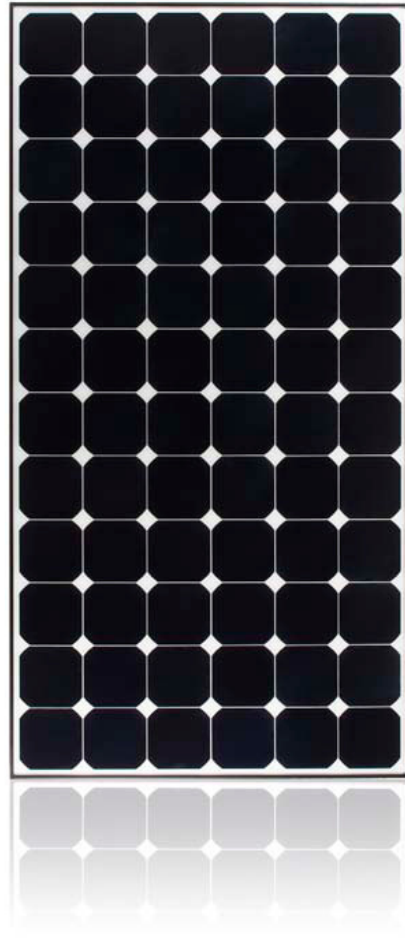

FEATURES

» **High Efficiency**

Industry leading panel efficiency of 17.3%

» **More Power**

Delivers up to 50% more power per unit area than conventional solar panels and 100% more than thin film solar panels

» **Reduces Installation Cost**

More power per panel means fewer panels per install. This saves both time and money

» **Reliable and Robust Design**

Proven materials, tempered front glass, and a sturdy anodized frame allow panel to operate reliably in multiple mounting configurations

SunPower's High Efficiency Advantage - Up to Twice the Power

Comparable systems covering 1000 m² / 10,750 ft²

	Thin Film	Conventional	SunPower
Watts / Panel	65	165	215
Efficiency	9.0%	12.0%	17.3%
kWs	90	120	173



Melbourne

Sydney

Brisbane

Adelaide

Launceston

Phone our sales offices on 1300 727 151 for more information



Printed on recycled paper

SunPower 215 Solar Panel

Exceptional efficiency and performance

Electrical Data

Measured at Standard Test Conditions (STC): irradiance of 1000/m², air mass 1.5g, and cell temperature 25 C

Peak Power (+/-5%)	Pmax	215 W
Rated Voltage	Vmp	39.8 V
Rated Current	Imp	5.40 A
Open Circuit Voltage	Voc	48.3 V
Short Circuit Current	Isc	5.80 A
Maximum System Voltage	IEC, UL	1000 V, 600 V
Temperature Coefficients		
	Power	-0.38% /°C
	Voltage (Voc)	-136.8 mV/°C
	Current (Isc)	3.5 mA/°C
Series Fuse Rating		15 A
Peak Power per Unit Area		173 W/m ² , 16.1 W/ft ²
CEC PTC Rating		198.5 W

Mechanical Data

Solar Cells	72 SunPower all-back contact monocrystalline
Front Glass	3.2mm (1/8 in.) tempered
Junction Box	IP-65 rated with 3 bypass diodes
Output Cables	900mm length cable / Multi Contact connectors
Frame	Anodized aluminum alloy type 6063
Weight	15kg, 33lbs

IV Curve

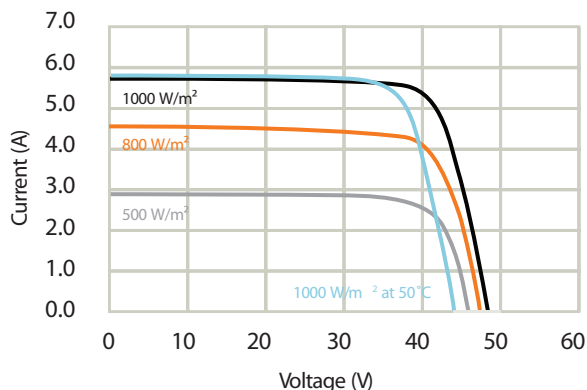

Current/voltage characteristics with dependence on irradiance and module-temperature.

Tested Operating Conditions

Temperature	- 40° C to +90° C (-40° F to +194° F)
Max load	50 psf (2400 pascals) front and back
Impact Resistance	Hail -25mm (1 in) at 23 m/s (52 mph)

Warranty and Certifications

Warranty	25 year limited power warranty 10 year limited product warranty
Certifications	IEC 61215 , Safety tested IEC 61730; UL listed (UL 1703), Class C Fire Rating

Dimensions

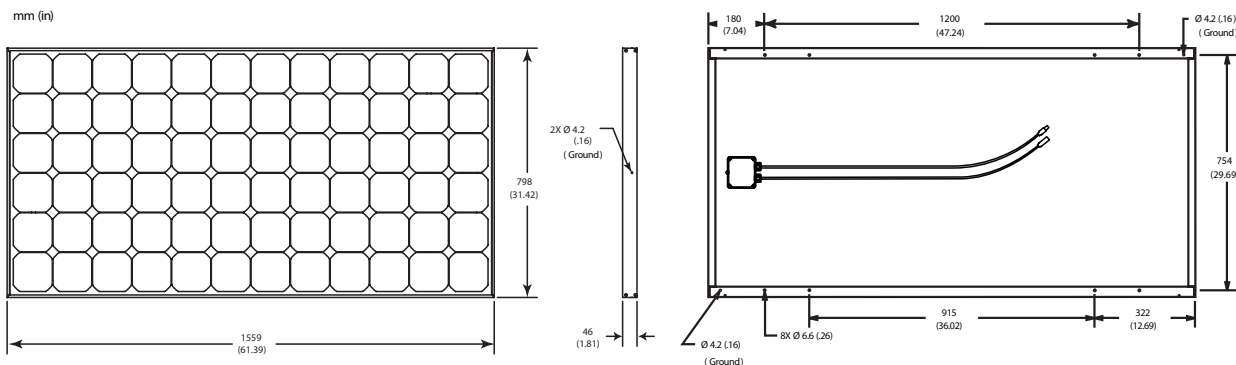

CAUTION: READ SAFETY AND INSTALLATION INSTRUCTIONS BEFORE USING THE PRODUCT. Go to www.energymatters.com.au for details

Melbourne

Sydney

Brisbane

Adelaide

Launceston

Phone our sales offices on 1300 727 151 for more information