

Energy Matters Airbreeze wind turbine stop switch

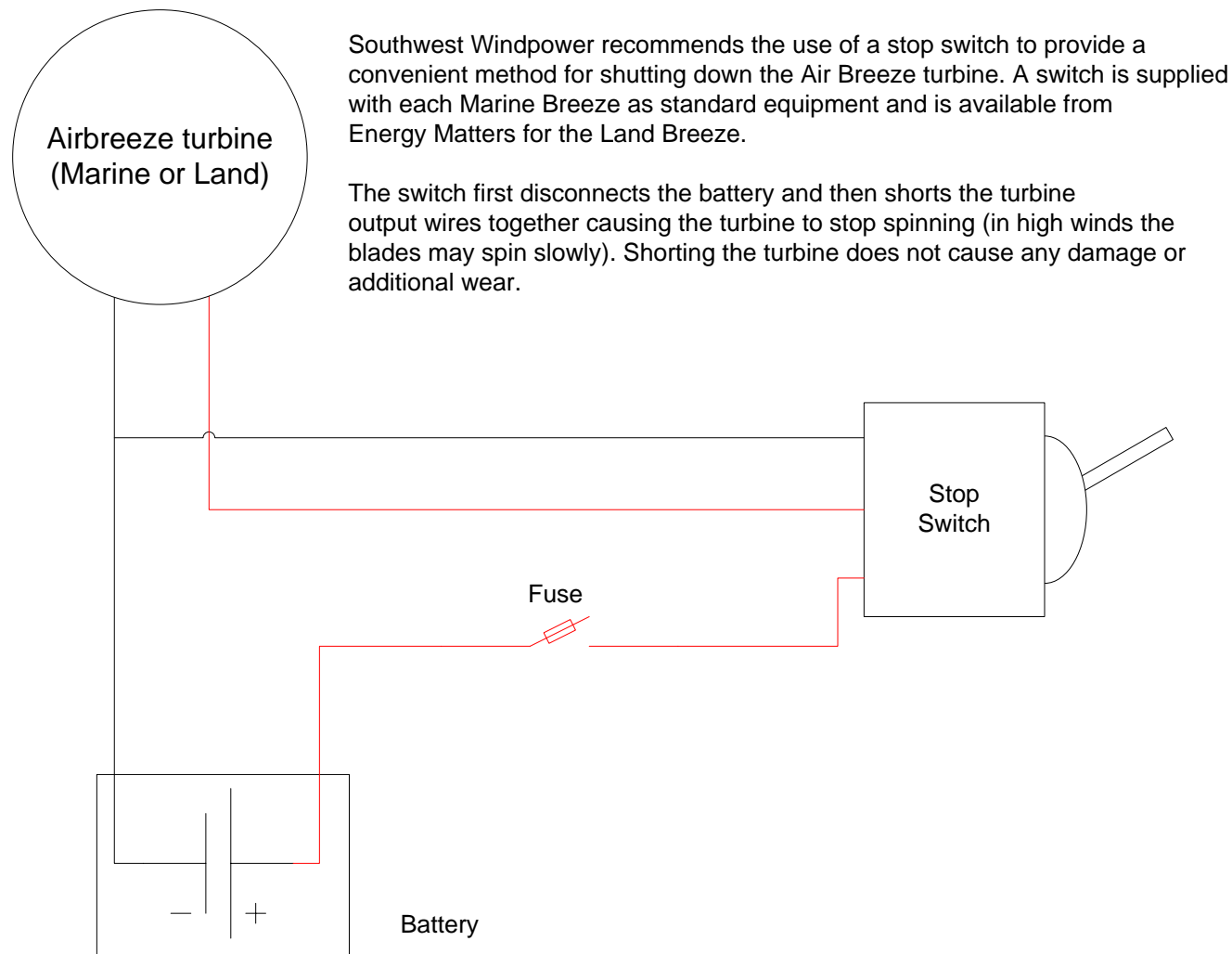

Southwest Windpower recommends the use of a stop switch to provide a convenient method for shutting down the Air Breeze turbine. A switch is supplied with each Marine Breeze as standard equipment and is available from Energy Matters for the Land Breeze.

The switch first disconnects the battery and then shorts the turbine output wires together causing the turbine to stop spinning (in high winds the blades may spin slowly). Shorting the turbine does not cause any damage or additional wear.



Energy Matters

63-69 Market Street South Melbourne
Victoria AUSTRALIA 3205

P: +61 3 9697 1900

F: +61 3 9997 1919

E: sales@energymatters.com.au

W: www.energymatters.com.au

Installation

Energy Matters provide this wiring diagram for installation as a recommendation and guide for the installation of equipment. It is to be used by experienced and competent users/installers only. Energy Matters cannot be held responsible for any equipment, property, or person damaged or injured as a result of improper installation.

Version date 17/4/10