

# HGL180-6B

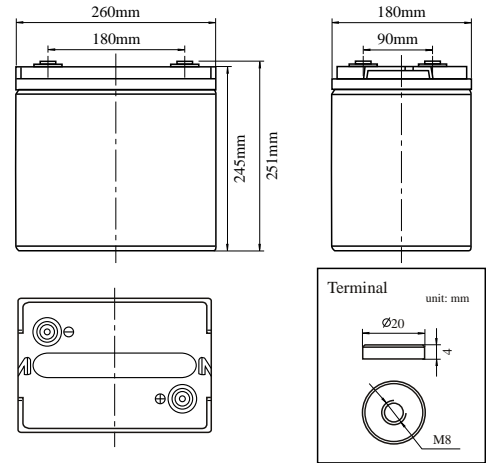

## Specifications

Nominal Voltage		6V
Rated Capacity(20 hour rate)		180AH
Dimension	Total Height (with terminals)	251mm(9.88inches)
	Height	245mm(9.65inches)
	Length	260mm(10.24inches)
	Width	180mm(7.09inches)
Weight		approx.32.1kg(70.77lbs)

## Characteristics

Capacity 77°F (25°C)	20 hour rate (9A)	180AH
	10 hour rate (16.74A)	167.4AH
	5 hour rate (30.6A)	153AH
	1 hour rate (108A)	108AH
	15 min rate (315A)	78.75AH
Internal Resistance	Full charged Battery 77°F (25°C)	1.5mΩ
Capacity affected by Temperature (20 hour rate)	104°F (40°C)	102%
	77°F (25°C)	100%
	32°F (0°C)	85%
	5°F (-15°C)	65%
Self-Discharge 77°F(25°C)	Capacity after 3 month storage	91%
	Capacity after 6 month storage	82%
	Capacity after 12 month storage	64%
Max. Discharge Current 77°F(25°C)		2700A (5S)
Terminal	Standard	F17
	Optional	
Charging (Constant Voltage)	Cycle	Initial Charging Current 36A Or Small 7.25V~7.45V/77°F (25°C)
	Float	6.8V~6.9V/77°F (25°C)

## Discharge characteristics 77°F(25°C)

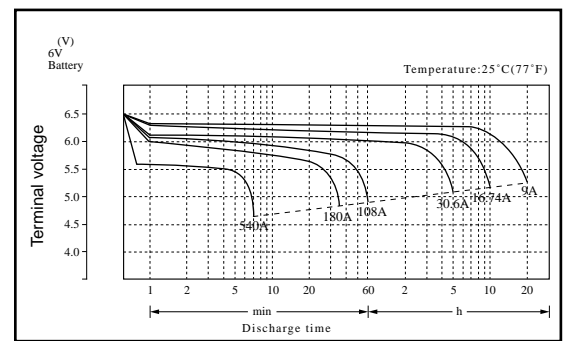

## Duration of discharge vs. Discharge current

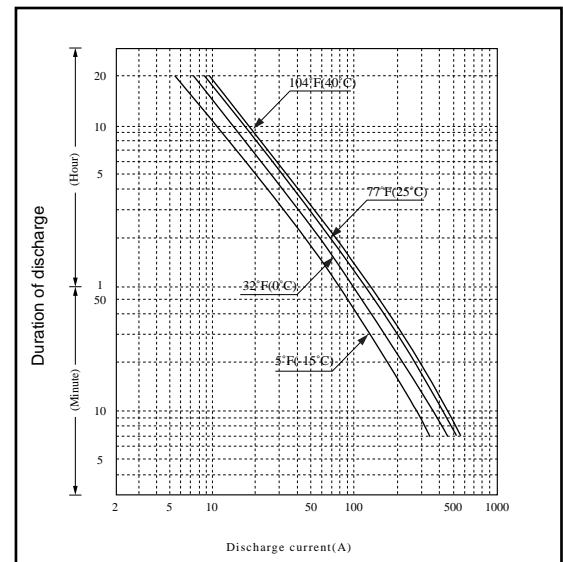

## Constant Power Discharge Watts Per Cell @ 77°F(25°C)

Cut off voltage V/cell	5M	10M	15M	30M	45M	1H	2H	3H	5H	8H	10H	12H	24H
1.60	940	735	602	386	288	227	133	92.7	62.2	40.8	34.6	29.8	15.4
1.65	897	709	585	380	284	226	132	91.9	61.8	40.8	34.6	29.8	15.4
1.67	887	700	576	377	282	223	132	91.0	61.6	40.8	34.6	29.8	15.4
1.70	843	673	557	372	279	221	131	90.5	61.4	40.8	34.6	29.8	15.4
1.75	797	637	534	362	272	220	130	90.0	60.9	40.4	34.2	29.8	15.4
1.80	747	601	510	352	264	219	129	89.4	60.4	39.9	33.8	29.4	15.4

**Note** The above data are average values, and can be obtained within 3 charge/discharge cycles. These are not minimum values.