

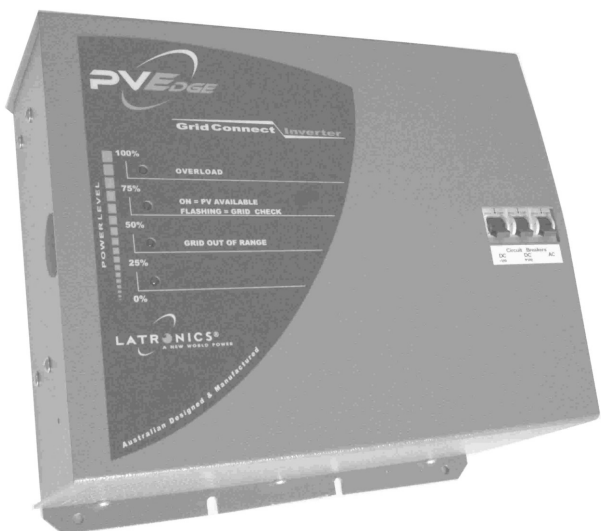

INSTRU TION ANUAL

and
WARRANTY REGISTRATION CARD



Latronics P.O. Box 73 Moffat Beach Qld 4551 AUSTRALIA
Ph 61 7 5491 6988
web: www.latronics.com email: technical@latronics.com



REPLY PAID MB 1
LATRONICS PTY LTD
P.O. BOX 73
MOFFAT BEACH QLD 4551
AUSTRALIA

NO POSTAGE REQUIRED IF
POSTED IN AUSTRALIA



WELCOME

Latronics products are all proudly designed, engineered and manufactured in Australia. As a specialist sine wave inverter company we produce Inverters for a diverse range of applications such as; mining, railways, telecommunications, marine, remote power, motor homes, and other industrial or commercial installations.

In order to produce the most reliable products available, *Latronics* Inverters have been designed to endure the most rugged terrain and the harshest conditions across the Australian continent.

All products are engineered using the latest high quality components and manufactured to stringent quality standards, thus ensuring *Latronics* customers all enjoy many years of trouble free operation.

It is important to us at *Latronics*, that our clients enjoy the maximum benefits from our Inverters in a safe and productive environment. So we strongly advise that you read through the next few pages of this manual, which explains all the modes of operation and relevant safety precautions for your new Power Inverter.

Please remember to complete and return your registration card on the last page of this manual to validate your 3-year warranty. Please retain your receipt as proof of purchase.

If your Inverter requires service or repair please complete the Warranty Repair Form on page 16

LATRONICS
PO BOX 73
MOFFAT BEACH Q 4551
PH: 61 7 5491 6988 FAX: 61 7 5491 6792
EMAIL: technical@latronics.com
WEB: www.latronics.com

IMPORTANT !
Please complete and return this Registration Card to validate your 3-year Warranty

Serial No..... Date card returned.....
- - - - -
 - - - - -

REGISTRATION CARD

Your 3-year warranty is only valid if this card is completed & returned within 3 months of the date of purchase.

Name:.....Post code:.....Serial No:.....

Date of Purchase:.....Supplier:.....

Email (optional):Comments:.....

- * Where is your Inverter being used? Residential Commercial
- * What Energy Source is connected to your Inverter? Solar Batteries Wind Other
- * Was your decision made because of?
Features Value for Money Appearance Recommendation Warranty Australian Made
- * How do you rate the service from your supplier? Fair Good Very Good Excellent
- * Did your new Inverter meet your expectations? Above Expectations Yes No

WARRANTY REPAIR FORM

.Your NamePhone.....

Email.....

Your Delivery Address

Your Postal Address

Inverter Serial No

Have you contacted your system installer? yes no

Do you have a battery bank yes no

What is the capacity of your Battery Bank?Amp hrs

Do you have Battery fuses installed? yes no

Have these Battery fuses been checked? yes no

Was the Inverter case hot when it failed? yes no

Which lights came on when Inverter failed? 100% Overload
 (please tick) 75% AC Grid
 50% AC Fault
 25%

What time did your Inverter fail? Day night

What were the weather conditions? sunny overcast rainy stormy

Have you disconnected the battery,
 then tried to turn on your Inverter? yes no

Please call *61 7 5491 6988 or email technical@latronics.com to obtain
 the address of your nearest service center and your RMA Number which is
 essential for efficient processing.

RMA Number.....

Have you attached proof of purchase yes no

We thank you for your time and patience. This information will help us
 determining the cause of failure and possible prevention methods.

TABLE OF CONTENTS

PAGE

INSTALLATION 2

DC WIRING 3

AC WIRING 5

SPECIAL FEATURES 6

DIP SWITCH SETTINGS 7

INVERTER OPERATION 8

SOLAR INPUT CONFIGURATION 10

FAULT FINDING 11

RADIO FREQUENCY INTERFERENCE 12

WARRANTY CONDITIONS 13

TECHNICAL SPECIFICATIONS 14

WARRANTY CARD 17



INSTALLATION

- Grid Interactive Solar Systems have become increasingly popular in recent years. These systems do not necessarily require batteries for storage and therefore can have a very simple configuration.

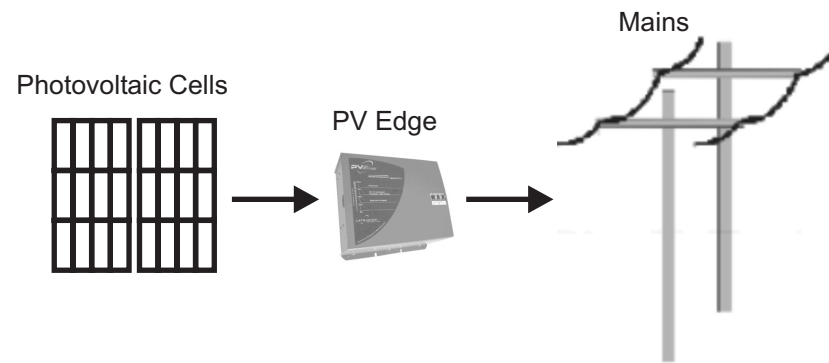

BEFORE INSTALLATION

- Ensure the Inverter has not been damaged in transit.
- The unit must be placed in a well ventilated and protected area, not exposed to the open environment, and free from contaminants (i.e. exhaust gases, sea air, dust etc.).
- The PV edge is designed for indoor installation in a suitable location where ambient temperature will not exceed rated values.
- As the PV edge has a wall mountable enclosure, ensure proper air circulation for cooling of the Inverter.
- Safety- DC solar input and AC grid are electrically and galvanically isolated via the Toroidal Transformer.

It is important that all wiring in the installation complies with the relevant standards (AS4777) .

***Any work carried out is to be preformed by
Qualified and Licensed personnel.***

2

STATEMENT OF QUALITY ASSURANCE

The whole of the supplies have been subjected to the Quality System Requirements in accordance with the conditions of AS/NZS ISO 9002: 1994.

***All items are manufactured with full traceability.
All PV Edge Inverters conform to the C-Tick mark for the EMC emission standard EN55014.***



15

TECHNICAL SPECIFICATIONS

Maximum DC Input Power	1200W	2500W
Maximum DC Input Current	22A	22A
Maximum DC Input Voltage	100V	200V
Maximum Power Point Tracking Range	55VDC - 90VDC	110VDC - 180VDC
Automatic Turn ON (MPPT - ON)	70VDC	140VDC
Automatic Turn ON (MPPT - OFF)	54VDC	108VDC
Starting Operation	10W	10W
Number of Modules Per String	4x 12V modules or 2 X 24V modules	8 x 12V modules 4 X 24V modules
Reverse Polarity Protection	Short Circuit Diode Across DC Input Terminals	Short Circuit Diode Across DC Input Terminals
Output Data		
Output Power	1000W cont. (1100W Max)	2100W cont. (2200W Max)
Output Voltage Range	205 -265 Vac	205- 265 Vac
Output Frequency	50Hz tolerance +/- 1Hz	50Hz tolerance +/- 1Hz
Peak Efficiency	93 %	93 %
Night Time Power Consumption	NIL Automatically Disconnects from AC Grid	NIL Automatically Disconnects from AC Grid
Input/Output Isolation	3500V via Toroidal Transformer	3500V via Toroidal Transformer
Operating Temperature	- 10°C to 50°C	- 10°C to 50°C
Anti islanding Protection	Over/under voltage Over/under frequency Active phase shift	Over/under voltage Over/under frequency Active phase shift
General Data		
Status Indicators	Output power in 25% Increments Grid Monitoring - Stability check Solar Input ON Grid Fault Overload	Output power in 25% Increments Grid Monitoring - Stability check Solar Input ON Grid Fault Overload
Wall Mount Enclosure	Powder Coated Aluminum	Powder Coated Aluminum
Dimensions	330mm H x 296mm W x 150mm D	370mm H x 386mm W x 180mm D
Weight	11 kg	22 kg
Connections	Hardwire Junction Box	Hardwire Junction Box
Warranty	3 years	3 years
Standards		
	C-Tick AS3100, AS4777 EN55014 Certificate of Suitability	C-Tick AS3100, AS4777 EN55014 Certificate of Suitability

DC WIRING

The Inverter is designed to operate directly from a photovoltaic supply.

- If other sources of DC input are required e.g wind turbines, micro hydro turbines etc, a battery bank will be required with the Maximum Power Point Tracking (MPPT) disabled (see pg 7.)
- The DC input voltage is stated on the PV Edge compliance label and the technical specifications sheet within this manual. Check that the input voltage is within the required limits and does not exceed the maximum limit (see pg 14).
- Recommended minimum cable size for the DC Input is 4sqmm with an insulation rating of 0.6/1KV.
- Observe Polarity.
- The Inverter is fitted with DC circuit breakers for the positive and negative DC Input connections.
- Ensure the DC breakers are switched OFF when working on DC wiring.

SAFETY

Inverter Isolation and Safety

- * All Latronics Inverters have an isolation rating of 3500V between AC and DC via the Toroidal Transformer, which ensures extremely safe and risk free operation.
- * All the switching electronics and control circuitry are on the DC input.
- * The Circuit Breaker assembly ensures that when the Inverter is switched OFF, it is isolated from the DC Input and AC Mains.

Please refer to relevant Australian Standards for safety procedures

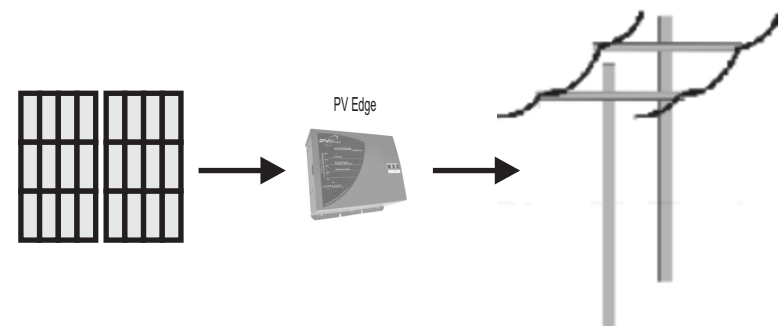

Solar Modules Only

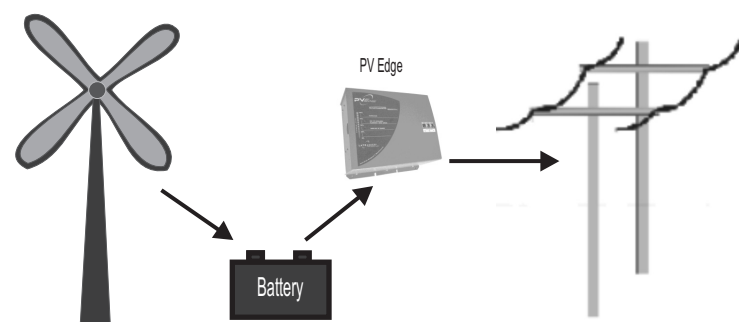

Wind Generator System

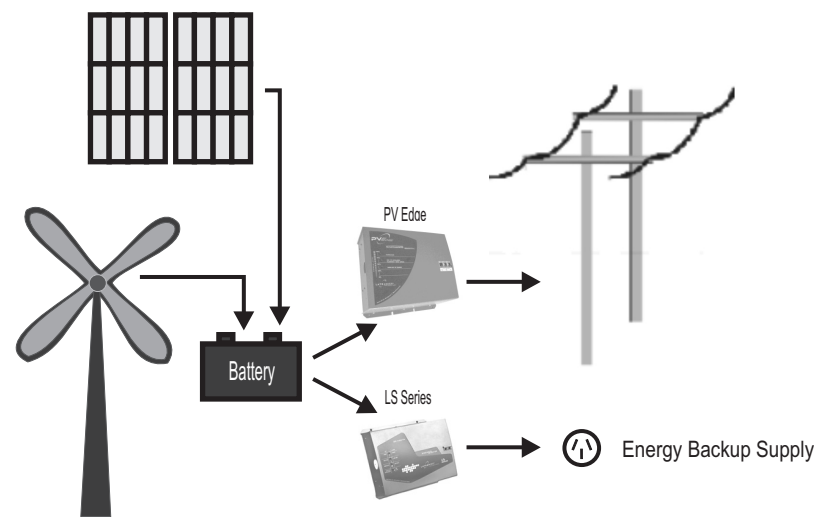

Multiple Renewable Energy Sources, with Emergency Backup Supply

WARRANTY CONDITIONS

All conditions and warranties expressed or implied by statute, common law, equity, trade, custom, usage, or otherwise howsoever are hereby expressly excluded to the maximum extent permitted by law. Where so permitted the liability of Latronics for a breach of condition or warranty that cannot be excluded is limited (at Latronics option) to the replacement or repair of the goods or of acquiring equivalent goods or the cost of replacing or repairing the goods or of acquiring equivalent goods. Latronics shall not be liable in any way whatsoever for indirect or consequential loss or damage whatsoever (whether based on tort or contract or otherwise)

- Damage caused by unauthorised repair, alteration or substitution of non-standard parts, incorrect installation, misuse, negligence, accident or similar cause, or usage other than in accordance with the operating instructions, is not covered under warranty.
- Unauthorised opening of the goods will render the Warranty invalid.
- The company may, at its discretion, agree to act as agent for the owner where delivery is requested and all costs for cartage and insurance will be for the owners account. All warranty work is ex-factory.
- The replacement of any part or labour involved will not have the effect of extending the period of the warranty of the goods.
- Any faulty part replaced under Warranty becomes the property of the Company for purposed of examination and claim under proprietary Warranty.
- Registration Card must be returned within 30 days from date of purchase to validate your 3-year warranty.
- Keep your receipt as proof of purchase, should any difficulties arise concerning the return of the registration card.
- Inverters are supplied by the manufacturer, or the manufactures agents, under the express condition that no responsibility is implied or accepted by the above parties for any damage to any appliance, equipment or property associated with the correct or otherwise operation of the Inverter.
- If service is required contact your local supplier/installer, or contact Latronics direct. Please ensure that you have completed the warranty repair form on page 16 to enable prompt processing.

RADIO FREQUENCY INTERFERENCE

Radio Frequency Interference (RFI) is a phenomenon that exists in modern society and is a problem in many areas of electronics. For Inverter users, RFI normally presents itself in the form of static and/or interference when listening to an AM radio and in unusual cases may interfere with TV reception.

Over the years Latronics has continued to invest significant time and effort in the reduction of RFI related emissions from the entire product range, so that they comply with the appropriate International and/or Australian Standards.

Even with this compliance, there are situations where RFI may still be a cause for concern, and can differ greatly from installation to installation. Accordingly, the following is a list of recommendations made to assist in the overall reduction of RFI.

1. **Separate DC and AC wiring.** Avoid running DC and AC cables in the same conduits and/or cable trenches. It is strongly recommended that DC and AC wiring be separated by the greatest distance possible. In extreme cases, the use of shielded conduit may be necessary.
2. **Minimize length of DC cabling.** DC cables can act as an aerial, therefore all such cables should be kept as short as is practicable. For best performance minimize DC cable length to Inverter and Batteries and if possible avoid the use of auxiliary DC loads.
3. **240Vac Earth.** For household installations, it is recommended that a "good" Earth Stake is located as nearby the Inverter as is possible.
4. **AM and HF Radios.** These types of radio equipment inherently suffer from all forms of RFI, especially when the received signal level is weak. In such cases reception can sometimes be improved by relocation of the radio itself, alternatively the use of an appropriate external antenna and co-axial cable may be necessary. External antennas should be located in a manner that ensures maximum signal strength whilst affording the greatest possible distance away from the Inverter and Batteries.
5. **Televisions.** TV signals are transmitted as FM waveforms. This type of signal fundamentally reduces the effects of RFI, therefore the use of a good antenna and feeder cable is normally sufficient to ensure quality reception. Locating the television as far as possible from the Inverter may also improve picture clarity.

AC WIRING

- * Make sure the Inverter is switched OFF before working on the mains wiring. Turn the AC Circuit Breaker switch into OFF position.
- * The active and neutral of the AC output are electrically isolated from the battery negative, battery positive, and earth connections.
- * The Inverter AC output is connected directly to the Transformer output winding.
- * Latronics Inverters have the AC output (active and neutral) floating with respect to the DC and Earth. The Earth connection is connected to the case only. This configuration provides the highest safety and most flexibility for installation wiring.
- * The active **A** and neutral **N** of the AC output are electrically isolated from the solar input and earth connections.
- * The earth **E** is connected internally to the Inverter case.
- * The Inverter is fitted with a Circuit Breaker for disconnection of the AC grid in the case of installation, fault or service. Ensure the AC breaker is switched OFF when working on AC wiring.
- * Suitable for *MEN* connection wiring.

WARNING:

The Inverter output is connected to mains electricity, thus it is important that all AC wiring complies with the requirements of the relevant wiring standards, (AS 3000, AS4777).

Any work carried out on AC/Mains wiring is to be performed by Qualified and Licensed personnel only.

SPECIAL FEATURES

Circuit Breakers

There are 3 breakers, DC positive , DC negative & AC grid.

Note: *Both DC breakers need to be turned ON to activate the Inverter. The AC breaker must be turned ON to allow the Inverter to connect to the grid.*

Night Time Disconnect

After dark when the solar input is no longer available the Inverter will automatically disconnect from the AC grid. This feature ensures that during the night, the Inverter cannot consume any power whatsoever while remaining idle. Upon sunrise the next morning when solar input becomes available again, the PV edge will automatically reconnect to the AC grid and begin generating power.

Parallel Operation

The PV edge automatically synchronizes to the AC grid, therefore the output of multiple units can all be connected together, and they will all be synchronized by the AC grid.

Note: *The Solar inputs of multiple unit Inverters are not to be paralleled.*

Maximum Power Point Tracking

The optimum power level from the solar input depends on the available solar modules. Even in cloudy weather with fluctuations in the solar radiation level, the PV Edge constantly monitors and tracks the optimum operating point to ensure maximum power from the solar modules is achieved.

Protection

The AC grid supply is constantly monitored for under and over voltage, over and under frequency, and anti islanding conditions via active phase shifts. The DC input is protected against over voltage, reverse polarity and over current via very fast current limit control. Isolation between the DC input and AC output is achieved via the Toroidal Transformer. The temperature of the transformer and switching devices are continuously monitored. The Inverter is fitted with a cooling fan, which is temperature controlled and only operates when required.

Maintenance Cycle

When in Battery mode (MPPT disabled) a maintenance cycle is performed every 30 days. This is a short boost cycle for sealed batteries or an equalize charge for flooded cells. In this mode the bottom LED will flash slowly until the cycle is completed.

FAULT FINDING

Should the Inverter appear to be malfunctioning we suggest the following to eliminate any external problems.

- Turn the Inverter OFF by switching the DC & AC Circuit Breakers OFF. Leave OFF for 60 seconds.
- Reconnect the DC Solar Input by switching both DC breakers ON. All lights on the Inverter should come ON for 1 second at power up and then go OFF. The 3rd light should remain ON to indicate the Solar Input is available. Solar Input voltage needs to be above the automatic turn ON voltage, see pg 14, for the light to turn ON. If the light does not illuminate check Solar Input for correct operation.
- Next reconnect the AC grid by switching the AC breaker ON. After 20 seconds the 3rd light should begin flashing to indicate Inverter reconnecting to the AC grid. The light will flash for approx 90 seconds while the PV Edge checks that the mains voltage and frequency are stable. Should the light not begin flashing check if the AC grid is present.
- After the 3rd light stops flashing the Inverter will begin feeding power into the AC Grid.

HELPFUL HINTS

- Make certain that you understand the operation of the Inverter.
- Remember that it has automatic reconnection to the AC grid.
- Make sure leads and terminals are not corroded, loose or faulty in any way.
- Make sure Circuit Breakers or switches are reset properly. If unsure switch OFF and ON again.

SOLAR INPUT CONFIGURATION

PVE 1200

Panel Power At 25°C	Module Type	Number of Panels Per String	No. of Strings	Solar Input Power
75W	12V	4	4	1200W
90W	12V	4	3	1080W
100W	12V	4	3	1200W
125W	12V	4	2	1000W
140W	24V	2	4	1120W
150W	24V	2	4	1200W
165W	24V	2	4	1320W
180W	24V	2	3	1080W

PVE 2500

Panel Power At 25°C	Module Type	Number of Panels Per String	Number of Strings	Solar Input Power
90W	12V	8	3	2160W
100W	12V	8	3	2400W
110W	12V	8	3	2640W
125W	12V	8	2	2000W
140W	24V	4	4	2240W
150W	24V	4	4	2400W
160W	24V	4	4	2560W
165W	24V	4	3	1980W
180W	24V	4	3	2160W

Note 1: The DC input is suitable for connection to solar modules only, when MPPT is enabled.

Note 2: Do not exceed recommended Maximum DC Input Power.

Note 3: All solar modules should be of the same type and brand. Therefore the maximum power point and voltage variation with temperature are consistent for all modules, which will ensure maximum system output.

DIP SWITCH SETTINGS

Switch 1 -MPPT / Battery mode

In the ON position (**default**) the Maximum Power Point Tracking is enabled. This is required when the DC input is Photovoltaic Solar Modules only. In the OFF position the Maximum Power Point Tracking is disabled and the voltage tracking will operate at a fixed voltage of 54V (PVE1200) or 108V (PVE2500). This setting is required in a system where a 48V (PVE1200) or 96V (PVE2500) Battery Bank is required on the DC input.

Switch 2 - 50/60 Hz

In the ON position the Inverter is set for 60Hz operation. In the OFF position (**default**) the Inverter is set for 50Hz operation.

Switch 3

Battery type selector not used if switch 1 is ON.
ON = Gel/SLA battery.
OFF = Flooded battery. (**default**)

Switch 4

Must be in OFF position (**default**) for normal operation. The ON position is a factory AC test setting.

Switch 5

Must be in the OFF position (**default**) for normal operation. The ON position is a factory DC test setting.

Switch 6

Not used.

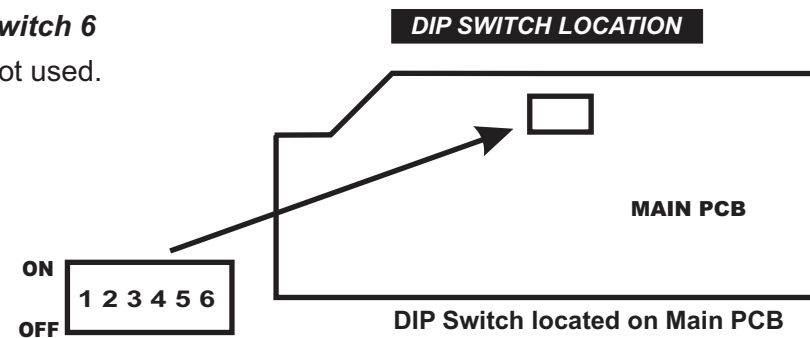

WARNING:

Due to dangerous voltages existing inside the unit, make sure the circuit breaker switch are turned off before opening the unit. Only qualified Trades Persons are permitted to adjust these settings.

INVERTER OPERATION

When the Inverter is switched on all 4 LED'S light up for 1 second while the microprocessor performs a start up and system check procedure.

100% Light (Overload)

This light illuminates when the power level is between 75% - 100%. This light also indicates overtemp/overload. In this mode the lower lights will be OFF and this light will flash.

75% Light (AC Grid)

This light will be ON when the power level is between 50% -75%.

This light also has 2 other modes of operation.

When in either of these 2 modes the bottom light will be OFF.

This light will be ON when the solar input is present and the AC grid is disconnected and/or awaiting reconnection.

This light will FLASH for 90 seconds when the inverter initially connects to the AC grid and performs a voltage and frequency stability check before feeding power into the AC grid.

50% Light (AC Fault)

This light will be ON when the power level is between 25% - 50%. When an AC fault is present this light will FLASH and the bottom light will be OFF.

25% Light

This light will be ON when the power level is between 0% - 25%.

Indicator Lamps

The 4 lights on the front panel indicate the Inverter power level in increments of 25%

LED 4 -100% (top Led).

LED 3 - 75%.

LED 2 - 50%.

LED 1 - 25%. (Bottom Led).

If the Inverter were supplying 60% of Full power then Led's 1, 2 & 3 would be illuminated.

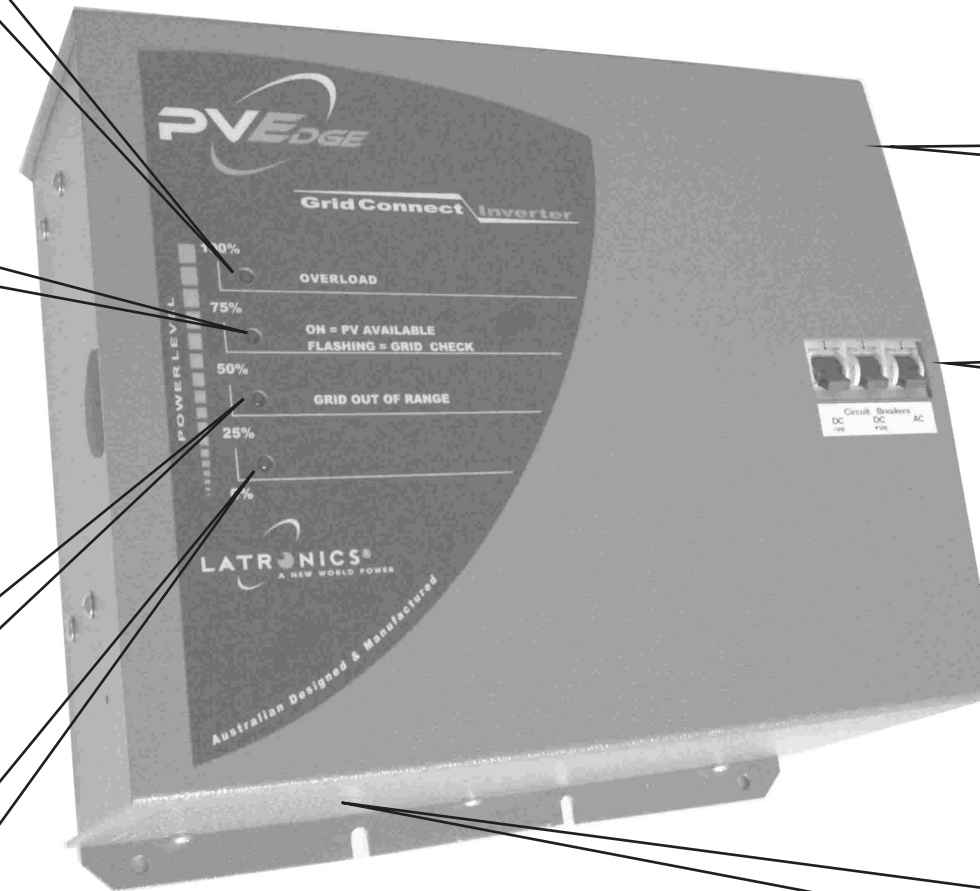

Hardwire - 3 Terminal Output Junction Box

For distribution of AC output power, e.g Connection to AC grid.

Circuit Breakers ON - OFF switch

1xAC & 2xDC Circuit Breakers.

Hardwire-3 Terminal Input Junction Box

For connection of DC Input Power from Solar Panels or Battery Bank.

Fan

If the temperature inside the Inverter reaches preset levels, the variable speed fan will switch on initially in low speed and then into higher speed if the temperature continues to increase. Obstruction of the air intake and output will reduce the power rating of the Inverter.