

# SELECTRONIC AUSTRALIA

## SE42 OWNERS MANUAL

<b>Contents:</b>	<b>Page</b>
<i>INTRODUCTION</i> .....	2
<i>WARRANTY CARD</i> .....	2
<i>INSTALLATION</i> .....	2
<i>CONNECTION OF AC AND DC WIRING</i> .....	4
<i>OPERATION</i> .....	5
<i>LIQUID CRYSTAL DISPLAY</i> .....	5
<i>STATUS</i> .....	5
<i>READINGS</i> .....	6
<i>SET PARAMETERS</i> .....	6
<i>OVERLOAD SHUTDOWN AND ALARMS</i> .....	8
<i>HANDY HINT</i> .....	9
<i>FAULT FINDING</i> .....	10
<i>SYSTEM MAINTENANCE</i> .....	11
<i>SE42 MAINTENANCE</i> .....	11
<i>BATTERY MAINTENANCE</i> .....	11
<i>SE42 ELECTRICAL SPECIFICATIONS</i> .....	12
<i>RADIO FREQUENCY INTERFERENCE</i> .....	13
<i>APPENDIX A DIAGNOSTICS &amp; ALARM LOG</i> .....	14
<i>APPENDIX B FLOW DIAGRAM FOR DISPLAYS AND SETTINGS</i> .....	16
<i>APPENDIX C FLOW DIAGRAM FOR DIAGNOSTICS</i> .....	16
<i>WARNING</i> .....	18
<i>PRODUCT WARRANTY and CONDITIONS</i> .....	18
<i>SELECTRONIC AUTHORISED SERVICE NETWORK</i> .....	19

## INTRODUCTION

Thank you for your purchase of the Selectronic Sine wave inverter, model SE42.  
Your SE42 is a state-of-the-art high performance TRUE SINE WAVE DC-AC Inverter.

Many hours of development time have been invested in the SE42 so that we can provide you with a reliable high quality inverter. The output from your SE42 is as good as, if not better than mains power. If looked after properly, the SE42 will give you many years of reliable service.

## WARRANTY CARD

Before proceeding any further, it is extremely important that you complete your warranty card NOW. This will enable us to immediately register your 5 year warranty period. By accurately completing your warranty card, you will provide us with valuable information that will assist us in keeping up with your alternative energy needs. Please take a few moments to fill in the warranty card. Your efforts will be greatly appreciated.

## INSTALLATION

The installation of your inverter is extremely important. Failure to follow the recommended installation instructions may void your warranty. If in doubt, ask your supplier.

After unpacking, check for any damage which may have occurred during transit. If there are any signs of damage, contact your supplier immediately.

The Inverter must be installed in a dry, cool, dust-free environment.

Please leave at least 300mm clearance around the sides and top of the Inverter and approximately 200mm at the rear as this will aid the natural cooling of the Inverter. The air vents on the underside of the SE42 also need to be kept clear of obstructions.

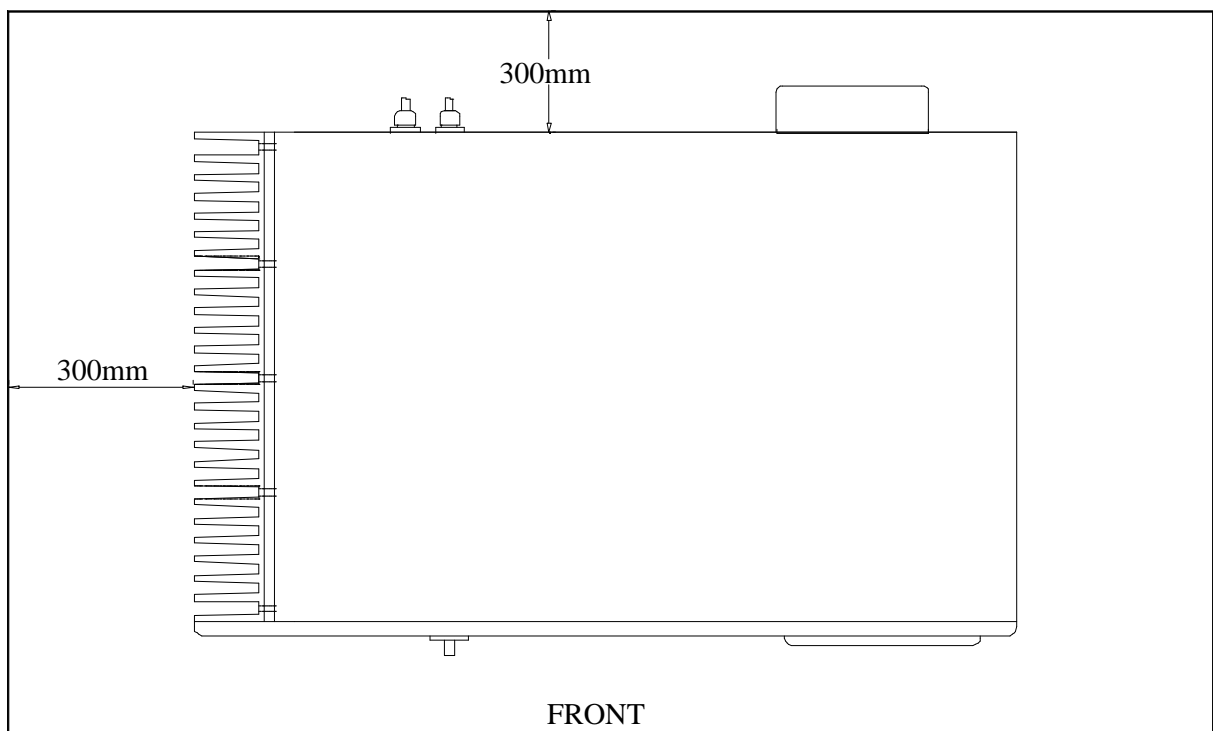

You must have a suitable 48V DC battery bank which is maintained and operated to the battery manufacturer's recommendation. To ensure operation to SE42 specification, the battery bank should have a minimum capacity of 700 ampere hours at the 100 hour discharge rate 48V systems (ask your supplier if in doubt). Smaller capacity batteries can be used but may result in degraded performance of the SE42 under heavy surge conditions.

**SYSTEM DIAGRAM**

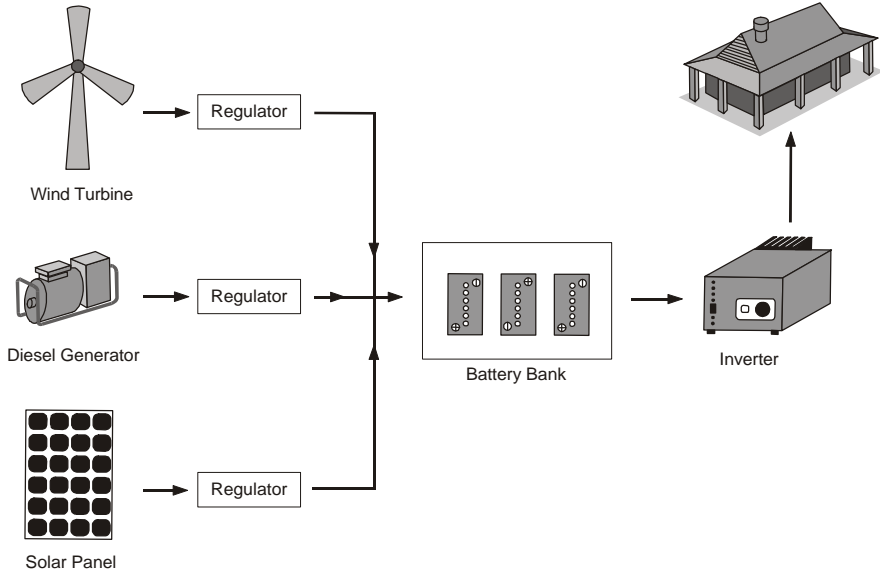

**Installation Example**

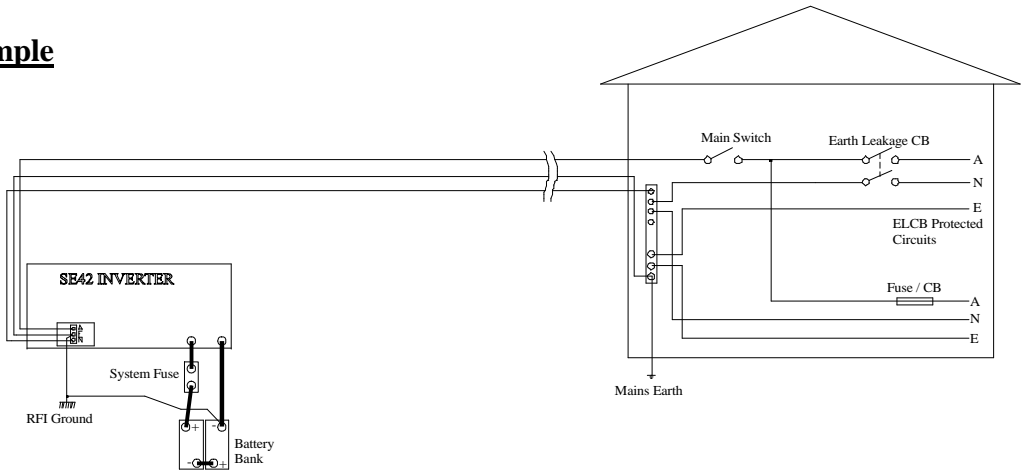

**\*SYSTEM FUSE**

A system fuse is an extremely important part of any power system, this fuse is designed to give one point of complete disconnect in case of a serious fault. The fuse should have a sufficient rating so as not to blow under heavy load conditions. Your inverter will normally be the biggest load in your system, if this is the case a motor start fuse equal to or slightly higher than the maximum continuous current of the inverter should be used.

If in any doubt see your supplier or installer.

## CONNECTION OF AC AND DC WIRING

**IMPORTANT:** Before making any wiring connections, check that the circuit breaker on the front panel is in the OFF position, i.e.; LEVER DOWN.

Your electrician should firstly connect the AC wiring via the three terminal rear junction box. Carefully observe the correct connections. Please refer to the diagram overleaf.

BROWN	ACTIVE	(red dot, top connector)
GREEN/YELLOW	EARTH	(E, centre connector)
BLUE	NEUTRAL	(Bottom connector)

The lid of the junction box has knockouts to allow conduit entry. Make sure this connection is tight and safe. Re fit junction box cover.

**NOTE:**  
**ALL AC WIRING MUST BE CARRIED OUT BY A LICENSED ELECTRICIAN AND MUST CONFORM TO AS3000 WIRING REGULATIONS, OR RELEVANT STANDARDS.**

**NEVER ATTEMPT TO HARD WIRE A HOUSE VIA THE FRONT PANEL GPO. THE RATING OF THE FRONT PANEL GPO IS 10A TOTAL LOADING ONLY.**

Verify that the circuit breaker on the front panel is in the OFF position, LEVER DOWN.

Now connect the battery cables.

RED	BATTERY POSITIVE (+)
BLACK	BATTERY NEGATIVE (-)

These connections should be tight. If using nuts, bolts and washers, they should be stainless steel. At this point re-check the connections before proceeding any further.

**NOTE:**

**IF THE SE42 EMITS A VERY LOUD TONE, THE BATTERY LEADS HAVE BEEN CONNECTED IN REVERSE. IMMEDIATELY DISCONNECT THE LEADS AND RECONNECT WITH THE CORRECT POLARITY. DO NOT, UNDER ANY CIRCUMSTANCES, TURN ON THE BREAKER WHEN THE BUZZER IS SOUNDING AS PERMANENT DAMAGE TO THE SE42 WILL RESULT.**

If all is well you can now switch the circuit breaker ON.

## OPERATION

When you first apply power, the SE42 will be in STANDBY mode. There will be a quiet pulsing sound. The SE42 is now ready for use.

### LIQUID CRYSTAL DISPLAY

The liquid crystal display and key pad on the front panel of the SE42 will provide you with vital information about your power system , whilst allowing you to set a number of parameters within the SE42.

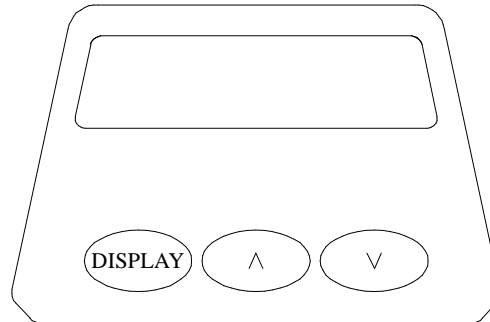

### STATUS

When you turn on the SE42 the inverter STATUS will be displayed. The inverter can have one of three status conditions. When first turned on it will show STANDBY mode.

Status: STANDBY Inverter: OFF
----------------------------------

Status: CONT Inverter: ON
------------------------------

Status: RESET Inverter: OFF
--------------------------------

When this screen is displayed, the Status can be changed by pressing the UP or DOWN arrow keys. Each time the UP key is pressed, the status will change from STANDBY to CONT to RESET and back to STANDBY where the DOWN key will change the Status in the reverse order.

The second line indicates if the inverter is ON or OFF. When ON the inverter is supplying 240V mains power. During standby, OFF is displayed on the second line, reverting to ON when a load is sensed and the inverter starts.

**STANDBY** mode means that the SE42 is producing pulses of power to sense when an appliance is switched on. This is called the demand start because as soon as the appliance is switched on, the SE42 will turn on and provide full power to the appliance.

The inverter will drop back into standby mode once all loads have been switched off for longer than 10 seconds. After this time, the SE42 will return to pulsing or demand start mode waiting for another load to turn on.

This feature is extremely important as it conserves valuable battery power when no appliances are on. The amount of power or load that the Inverter needs to “start up” is adjustable, see page 6 for details.

**CONT** mode (CONTINUOUS) means that the Inverter will be on at all times regardless of whether appliances are connected or not. This situation is useful if you have small loads such as a VCR or digital clock that requires 24 hour power, or if loads are too small to be sensed in the STANDBY mode. The only disadvantage is that when the appliances are off the SE42 will be drawing more power than it would in STANDBY mode.

**RESET** mode electronically shuts down the inverter. When placed in this mode, any overload or shutdown conditions are also reset. This situation will be explained in more detail in a later section.

## READINGS

The next five displays provide the following information:

### TIME AND DAY

```
MON: 5:20
Time of Day
```

This reading the current time and day. The time is in 24Hr mode.

### BATTERY VOLTS

```
Batt Volts: 49.2V
Battery Volts
```

Displays the DC Battery volts. This provides you with an indication of the condition of your battery bank.

### AC VOLTS

```
AC Volts : 240V
AC Loads
```

This reading gives an indication of the AC voltage produced by the inverter. This reading will vary depending on how large a load is connected or if the battery voltage is very low.

### AC AMPS

```
AC Amps : 2.5A
AC Loads
```

The AC Amps reading shows the total current drawn from the AC output by the appliances connected to the inverter. This reading is also handy for knowing how much power a particular appliance draws.

### COMPOSITE DISPLAY

```
49.2V 240V 2.5A
Batt --AC OUT--
```

Displays the DC Battery volts, the AC output volts and the AC output current.

## SET PARAMETERS

In this menu a number of parameters within the SE42 which can be changed via the front panel push buttons to allow you to tailor the SE42 inverter to suit your system requirements.

*To enter this menu you must hold down the DISPLAY key for at least 1 second whilst in any of the "Readings" displays.*

- The value of the parameter displayed can then be modified by pressing the UP or DOWN keys.
- Pressing the DISPLAY key will take you to the next parameter to be set.
- At the end of the set parameters menu you will be returned to the "Readings" displays.

**Please note:** Once the parameters have been successfully entered (i.e. you have stepped right through the set parameters menu and are back in the readings display) then if the inverter is turned off or the DC power is disconnected from the inverter, the "parameters" which have been entered will be saved and held in permanent memory.

## SETTING CODE

Setting Code:NO  
-Set Parameters-

When this is set to YES, the settings require a coded key sequence before they can be entered. The key sequence is always DOWN, UP, DOWN, DOWN followed by the DISPLAY key

## HOUR SETTING

Hour: 1  
--Set Time--

Enables you to enter the current hour setting. Pressing DISPLAY button will take you to the next display.

## MINUTE SETTING

Minute: 15  
--Set Time--

Enables you to enter the current minute setting. Pressing DISPLAY button will take you to the next display.

## DAY SETTING

Day : SUN  
--Set Time--

Enables you to enter the current day setting. Pressing DISPLAY button will take you to the next display.

## BUZZER

Buzzer : ON  
-Set Parameters-

This display allows you to select whether the audio alarm will sound during an overload or other alarm condition. Use the UP or DOWN keys to toggle between ON or OFF state. This is set to ON at the factory.

## BUZZER LOCKOUT

Buzz lockout:OFF  
-Set Parameters-

This display allows you to select whether the audio alarm will sound during the lockout period. This will prevent the alarm from sounding during the night or other periods when you want silence.

## BUZZER LOCKOUT START

Lockout On:22:00  
-Set Parameters-

This display allows you to set the lockout start time. The buzzer will not sound during an alarm condition after this time. This time is 24Hr mode.

## BUZZER LOCKOUT END

L'out off: 6:00  
-Set Parameters-

This display allows you to set the lockout end time. The buzzer will be able to sound during an alarm condition after this time. This time is 24Hr mode.

## DS SENSE

DS Sense : 6W  
-Set Parameters-

Demand Start: When in STANDBY mode the inverter will require a load of 6 watts or greater to turn on to full 240V power. This setting can be adjusted between 1 to 30 watts. In most cases the default setting of 6W would be suitable. If there is a load which the SE42 won't sense then reduce this value until the SE42 starts. Alternatively if there is a small load that keeps the SE42 ON, then increase this value. You may need to try a few different settings to find the most appropriate value for your installation. Use the UP or DOWN keys.

## LO DC VOLTS

```
Lo DC Volts:44.0  
-Set Parameters-
```

The SE42 will cut out and a message will be displayed if the battery voltage falls below this setting for more than 10 seconds. The inverter will restart if reset, or when the battery volts rise above the '**Lo DCV on**' setting. Use the UP or DOWN keys to change the value. Default value is 44.0 volts.

## LO DCV ON

```
Lo DCV on: 48.0V  
-Set Parameters-
```

The SE42 will restart after a Low Battery Volts cut out when the battery volts rise above this setting. Use the UP or DOWN keys to change the value. Default value is 48.0 volts.

## HI DC VOLTS

```
Hi DC Volts: 68.0  
-Set Parameters-
```

When the battery volts exceeds this setting, the SE42 will cut out instantaneously. Use the UP or DOWN keys to change the value. Default value is 68.0 volts.

## AC OUTPUT VOLTS

```
AC Volt : 240V  
-Set Parameters-
```

Allows the AC output voltage to be set in a range of 220V to 240V if an output voltage other than 240V is required. Users outside Australia should check with their system designer for the correct setting. Use the UP or DOWN keys to change the value. This value is set to 240V at the factory.

## END SETTINGS

```
End Settings  
-Set Parameters-
```

Indicates the end of the set parameters menu. Pressing the DISPLAY key will return you to the readings menu and save your settings.

## OVERLOAD SHUTDOWN AND ALARMS

The SE42 has seven alarm and overload conditions. If one of these conditions occurs, a message will be displayed. If there is more than one alarm condition the display will alternate between messages.

The alarm message will remain on the display for the duration of the shutdown and until acknowledged by pressing a key even if the alarm condition has ended (i.e. your battery voltage might have dropped to a low voltage for a short while but has since come back up to normal voltage). After a shutdown the inverter will automatically reset after 1 minute.

**Important Note:** The alarms are also stored in memory allowing you to go back and review them at a later date for any trends. The Diagnostics section explains how to view these logged alarms.



## DC VOLTS HI

Hi DC Volts:66.0  
\*\*Press a Key\*\*

This message is displayed and the inverter shuts down if the battery voltage rises above the **Hi DC Volts** setting. The inverter will automatically restart when the battery voltage drops below this value. The present battery voltage is also displayed.

## DC VOLTS LO

Lo DC Volts: 39.0  
\*\*Press a Key\*\*

This message is displayed and the inverter shuts down if the battery voltage drops below the '**Lo DC Volts**' setting for more than 10 seconds. The inverter will automatically come on again when the battery voltage rises above the '**Lo DCV on**' voltage or if the inverter is manually reset (via the STATUS display, see page 5). The present battery voltage is also displayed.

## AC VOLTS HI

AC Volts Hi  
\*\*Press a Key\*\*

If a system fault causes the AC voltage to go too high, then this message is displayed.

## AC OVERLOAD

AC overload  
\*\*Press a Key\*\*

If the inverter has sustained a high current for an extended period of time the inverter will shutdown and display this message. The SE42 will automatically reset after 1 minute.

## AC OVER CURRENT

AC over current  
\*\*Press a Key\*\*

A severe AC current overload or a short circuit on the AC output will cause the inverter to shutdown and display this message. The SE42 will automatically reset after 1 minute.

## TX TOO HOT

TX Too Hot: 122C  
\*\*Press a Key\*\*

If the internal transformer reaches its maximum operating temperature, the SE42 will shutdown to protect the internal components. The SE42 will restart again only when the temperature drops to a safe level. The present temperature of the transformer is also displayed.

## HS TOO HOT

HS Too Hot: 90C  
\*\*Press a Key\*\*

If the black external heatsink reaches its maximum operating temperature (80°C), the SE42 will shutdown to protect itself. The SE42 will come on again when the temperature drops to a safe level (70°C). The present temperature of the heatsink is also displayed.

## HANDY HINT

It is very important that you become familiar with the functioning of your Inverter. Since most Inverters are not within sight, it is not always easy to know what STATUS your inverter is in. An easy way to determine this is to plug a small child's night light (neon type) into a power point which is easily visible, or replace any power point with a neon indicator type. This will indicate the inverter's operation by flashing when the inverter is pulsing and remaining on when the inverter is brought on by a load.

## **FAULT FINDING**

### **1. INVERTER STAYS ON EVEN WHEN NO APPLIANCE IS BEING USED.**

Some appliances such as Microwave Cookers or Video Recorders still draw current when not in use. This is to power their displays.

This is a common problem known as a "phantom load", but it can be easily overcome with the SE42. When trying to isolate a phantom load these appliances will need to be switched off at the power point. Sequentially switch off appliances at their power points while checking to see if the inverter returns to demand start mode after a 10 second delay. See "Handy Hint" on page 9 if your inverter is located remotely. Once you have found the offending appliance, adjust the sensitivity of the demand start up (see "Set Parameters" on page 6 ) until the Inverter turns off. Once this is done re check that small loads will still bring the Inverter on when required.

### **2. INVERTER WILL NOT COME ON WHEN SMALL APPLIANCE IS SWITCHED ON.**

This means that your demand start sensitivity is set too high. With the appliance in question switched on, adjust the demand start sensitivity (see "Set Parameters" section on page 6) until the SE42 turns on.

### **3. INVERTER SHUTS DOWN DURING MIDDLE OF THE DAY AND COMES BACK ON LATE AFTERNOON.**

This is more than likely caused by high battery volts during peak charging times from solar panels. To overcome this, adjust the high voltage cutout of your SE42 (see "Set Parameters" on page 6); to the maximum voltage allowable. If this is still not high enough you may have a problem with either your batteries or your regulator. This could be potentially dangerous so we advise you to consult your system designer immediately.

### **4. INVERTER SHUTS DOWN WITH LOW VOLTS.**

If your SE42 has shut down because of low DC volts it could be due to the following:

- (1) A sustained large load could be causing the battery volts to drop below the SE42 cut out voltage.
  - (a) The Battery Bank is too small for the loads you wish to use - consult your system designer.
  - (b) A bad connection between the batteries and inverter due to a loose or corroded terminal. In this case, please refer to the maintenance section of this manual (on page 11.)
  - (c) One or more battery cells could be faulty - consult your battery supplier.
- (2) If your battery volts are below 48.0V with no loads connected, the batteries may require charging. Use a hydrometer to check the specific gravity of each cell. Consult your battery manual for the correct specific gravity (SG) readings.

### **5. INVERTER SHUTS DOWN DUE TO HS TOO HOT**

This is likely under sustained heavy load conditions since the SE42 shuts down to protect its internal components. The SE42 will shutdown at 80°C heatsink temperature and recover from shutdown when the temperature reduces to 70°C. If you believe that the load is not excessive, check around the Inverter case and heatsink for obstructions to air flow as this will cause the Inverter to heat up much quicker and shut down sooner than normal. Also check that the clearances around the SE42 are as specified in INSTALLATION on page 2.

### **6. INVERTER PULSES SLOWER THAN NORMAL WHEN IN STANDBY**

This means that the inverter has not been switched on for approximately 20 minutes and has gone into a power saving mode, thus pulsing at about half the normal rate.

## SYSTEM MAINTENANCE

To get the optimum performance from your SE42 power inverter, particularly under heavy appliance loads, it is essential that the battery bank and the DC wiring are all in good condition. The small amount of time spent on the below maintenance tasks will maximise the reliability of your system.

### SE42 MAINTENANCE

Periodic maintenance of the SE42 inverter involves little more than checking for unobstructed operation of the cooling fan, which is located at the rear of the inverter. Note that cooling air is drawn in through vents underneath the inverter.

Suggested inverter maintenance should include:

1. Check for unobstructed fan operation:  
Clear away any dust or foreign matter from the fan grill using a soft bristled brush.  
(Do not direct high pressure compressed air at the fan blades)  
Note that the fan is designed to come on during heavy power demand.
2. Check between fins of the heatsink and clean out any accumulated foreign objects, for example, insect nests.
3. Verify that the air flow beneath the chassis is not restricted.

## BATTERY MAINTENANCE

### **IMPORTANT:**

**When working on batteries of such high capacity it is essential that you wear protective clothing, some form of eye protection and rubber-soled work boots. Please regard your batteries with a great deal of caution, and if in any doubt, entrust this work to your installer.**

1. Every week, carry out a thorough visual inspection of all battery wiring, taking particular note of the condition of inter-connections between cells.
2. Check that the stainless steel inter-connecting bolts are tight and have minimal corrosion. If corrosion is evident, carefully follow the following procedure.
  - (a) Disconnect the system battery fuse before working on the battery bank.
  - (b) Unbolt the stainless steel bolts and nuts of any corroded connections and thoroughly clean the joint with a wire brush or file, taking extreme care not to short circuit any battery cells with any tools.
  - (d) Re-assemble and smear a small amount of Vaseline or similar grease over the surface of the joint to slow down any future corrosion.
3. Every month or as directed in your battery instruction manual, measure the specific gravity (SG) of each cell using your hydrometer, to ensure that all cells are performing correctly. Any serious imbalance should be reported to your system designer in case remedial action needs to be taken.

## SE42 ELECTRICAL SPECIFICATIONS

### INVERTER TYPE

PWM Full bridge power stage, with true sine wave AC output.

<b>SELECTRONIC SE42 INVERTER SPECIFICATIONS</b>		
<b>ELECTRICAL</b>		
<b>PARAMETER</b>	<b>SE42</b>	<b>CONDITION</b>
Output Power @ 25 °C Ambient	3600 watts 4600 watts 10,000 watts	Max Continuous 1/2 Hour Rating Max Surge
Output Power @ 40 °C Ambient	3300 watts 4200 watts 10,000 watts	Max Continuous 1/2 Hour Rating Max Surge
Voltage Input Range	40 - 68V DC	Range
Input Current	0.05A DC 0.4A DC 78A DC 210A DC	Stand By Inverter ON – No Load Max Continuous Max Surge
Demand Start Sensitivity	1-30W	User Adjustable
Response Time	1 Second Max	
Low Voltage Shutdown	38 - 49VDC	User Adjustable
High Voltage Shutdown	60 - 68VDC	User Adjustable
Output Voltage	Adjustable from 220 to 240V AC +/- 4%	@ Nominal DC Input, No Load to Full Load
Output Current	15A AC 41A AC	Max Continuous Max Surge
Output Wave Shape	True Sine Wave	
Output Frequency	50Hz +/- 0.01%	
Total Harmonic Distortion	< 4%	
Power Factor Limitations	Nil	
Input / Output Isolation	1875VAC	
Memory Retention	Permanent	
Operating Temperature Range	-10 °C - 50 °C	
Conforms to standards	AS 3100 (wiring), AS 3108, C tick	
<b>MECHANICAL</b>		
Size	500mm wide x 180mm high x 370mm deep	
Weight	29kg	
Weight Packed	32kg	
Input Lead Length	1.5 metres	
Output Wiring Method	Rear three terminal junction box with conduit knock outs	
Output Socket	Dual switched GPO	
Chassis	Powder coated zinc steel (Wedgwood Blue)	
DC Isolation	Single Pole Circuit Breaker	
Warranty	5 year parts and labour (Conditions apply)	

### Notes:

The above specifications are based on unity power factor.

The DC Input is electrically isolated from the AC Output.

Through a policy of continued development, specifications are subject to change without notice

## **RADIO FREQUENCY INTERFERENCE**

Radio Frequency Interference (RFI) can be a problem for owners of inverters. RFI in a domestic situation may produce noise or interference on a radio or TV receiver.

Considerable development time has resulted in a reduction of the RFI generated by the inverter to a level that complies with C-tick requirements. Compliance to this standard means RFI is low, but how well the inverter performs in a particular installation can vary. Below are some suggestions to help reduce the effects of RFI in your installation;

- It is recommended that the power system, including the inverter, be housed at least 15 metres from the home.
- Ensure an earth stake is placed as close to the inverter as possible and connected to the inverter via a short length of wire. See the “INSTALLATION” section of this manual for wiring.
- Avoid running DC cables into the home, if at all possible. If this cannot be avoided, run DC and AC in separate conduits separated by as much distance as practicable. All DC wiring cables should be kept together and be as short as possible.
- If your inverter is to be installed in a Mobile Home or similar, try to keep your inverter at least one metre away from your radio or audio equipment. The further the better.

## APPENDIX A    **DIAGNOSTICS & ALARM LOG**

The "Diagnostics" is a special set of displays which give additional information about the SE42. These are normally only used when advanced troubleshooting is undertaken. The "Diagnostics" section displays the transformer and heatsink temperature, demand start current and software version information.

"Diagnostics" is accessed by holding both UP and DOWN buttons together for more than 1 second during the display of any "Readings" screen.

The following display indicated that you are now in the Diagnostics menu:

```
Press DISPLAY
..Diagnostics..
```

The DISPLAY key takes you through the "Diagnostics" displays, eventually returning to the "Readings" display.

### **LOG WEEKS**

```
Log weeks:0
..Diagnostics..
```

This display is use with the Energy Management MKII during logging of system performance.

### **OVER CHARGE OF BATTERIES**

```
Overcharge:00%
..Diagnostics..
```

This display is use with the Energy Management MKII.

### **TRANSFORMER TEMPERATURE**

```
TX Temp: 75C
**Diagnostics**
```

This display is the operating temperature of the transformer inside the SE42 in degrees Celsius. Pressing DISPLAY button will take you to the next display.

### **HEATSINK TEMPERATURE**

```
HS Temp: 34C
**Diagnostics**
```

This displays the operating temperature of the heatsink. Pressing DISPLAY button will take you to the next display.

### **DEMAND START CURRENT**

```
D/S I : 524
**Diagnostics**
```

This gives a reading of the value read by the demand start sense circuit and can be useful during advanced demand start troubleshooting. Pressing DISPLAY button will take you to the next display.

## DEMAND START ZERO

D/S zero : 540  
\*\*Diagnostics\*\*

This gives the zero value read by the demand start sense circuit and can be useful diagnostic. Pressing DISPLAY button will take you to the next display.

## SOFTWARE VERSION

SELECTRONIC C  
SE42ii vv yyyy

This displays the revision of the software running your SE42. Please note that this software is Copyright to SELECTRONIC AUSTRALIA P/L and it is an offence to copy or duplicate any part of this program. This is the last screen in the "Diagnostics" and pressing the DISPLAY key once more will return you to the readings menu.

# APPENDIX B FLOW DIAGRAM FOR DISPLAYS AND SETTINGS

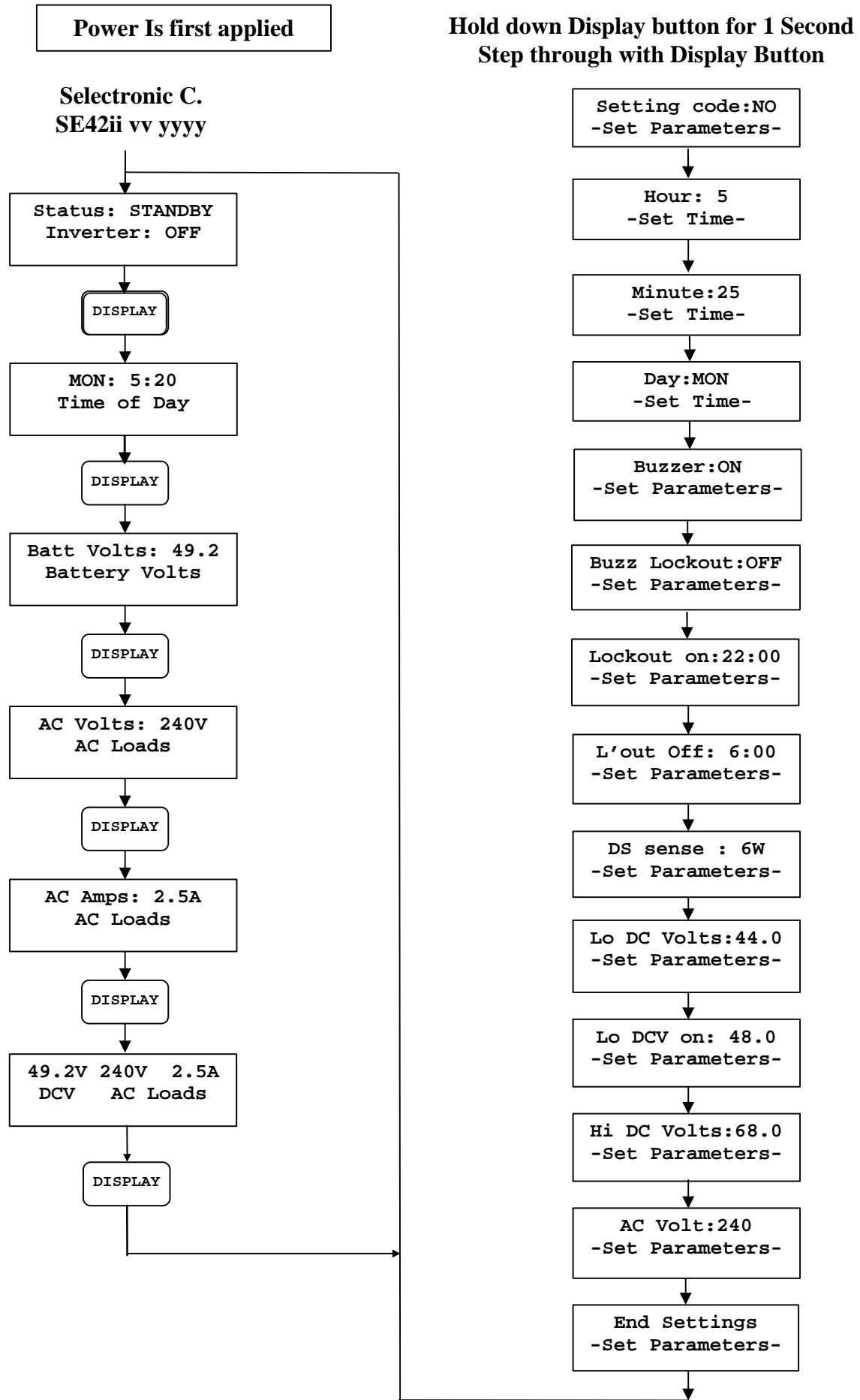



# APPENDIX C FLOW DIAGRAM FOR DIAGNOSTICS

Hold both UP and DOWN

buttons for 1 second

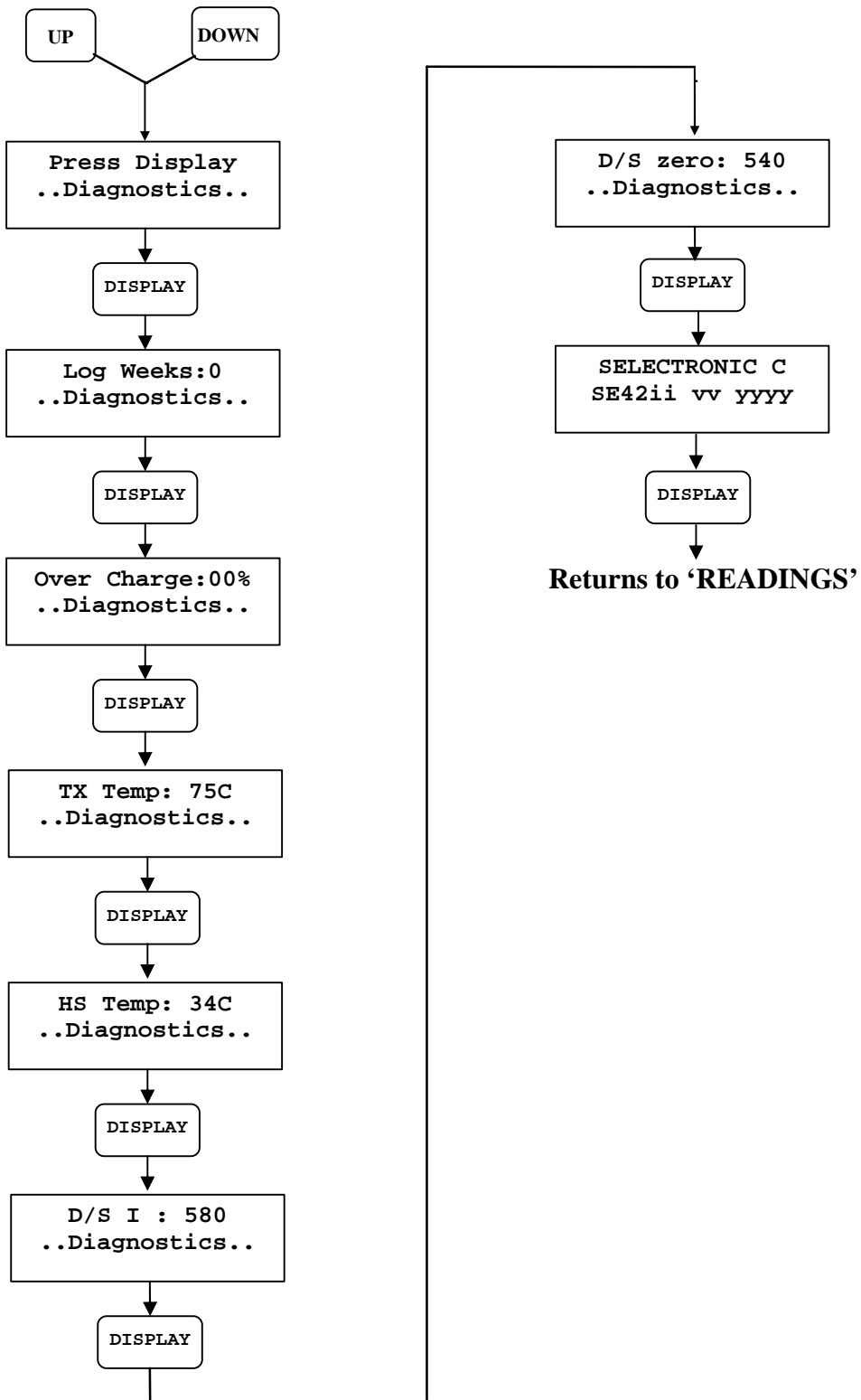

## WARNING

### **THE OUTPUT VOLTAGE FROM AN INVERTER IS JUST AS LETHAL AS LANDLINE POWER.**

It is necessary for your safety to ensure that all Remote Area power system installations meet and comply with the relevant provisions and requirements of AS3000 wiring standards and AC wiring is installed by a Registered Electrical Contractor.

## PRODUCT WARRANTY and CONDITIONS

These warranty conditions apply to the SE range of Inverters for sales within Australia and New Zealand.

This product is warranted by the manufacturer for a period of 60 months from date of purchase to the original purchaser only.

The manufacturer will bear the cost of parts and labour to repair any faults found within the terms and period of this warranty.

Faulty product or parts must be returned to Melbourne Australia at the owner's expense for claim under warranty. No allowance is made for the cost of labour or traveling time required to disconnect or reinstall faulty parts.

Cost of freight to return parts to the customer will be paid by the manufacturer, method of freight used will be determined by the manufacturer.

Under certain circumstances the manufacturer may allow on site repairs to be carried out. This will be at the manufacturers discretion and the manufacturer is not responsible for the cost of any labour or traveling time incurred.

Unless otherwise specified to the purchaser the benefits conferred by this voluntary warranty are additional to all other conditions, warranties, guarantees, rights and remedies expressed or implied by the Trade Practices Act in your state or territory.

All installation and user conditions as set down in the instruction manual must be strictly adhered to, failure to do so may void your warranty.

This product is not to be used for Life Support equipment.

Any faults caused by lightning, water or moisture ingress, faulty installation, using the product in a manner which it is not intended, vermin infestation, improper voltage, alterations to the product which affect its reliability or performance, or faulty generator sets will not be covered under warranty.

The manufacturer shall bear no responsibility for any consequential loss, damage or expense due to any malfunction of the product or the time it is out of service

The manufacturer will not be held responsible for any misleading or incorrect information conveyed by any salesperson or installer not directly employed by the manufacturer.

If service is required please contact your installer or retailer before taking any further action.

## SELECTRONIC AUTHORISED SERVICE NETWORK

---

Selectronic Australia  
Suite 5, 20 Fletcher Road  
Mooroolbark  
Victoria 3138  
Australia  
Ph: +61 3 9727 6600  
Fax: +61 3 9727 6601  
[www.selectronic.com.au](http://www.selectronic.com.au)  
[service@selectronic.com.au](mailto:service@selectronic.com.au)

Burley TV Service  
278 Edmondson Ave.  
Austral  
NSW 2171  
Australia  
Ph: 02 9606-0279

Rainbow Power Company  
1 Alternative Way  
Nimbin  
NSW 2480  
Australia  
Ph: 02 6689 1430  
Fax: 02 6689 1109

Solar Inverter Services  
13 Thirteenth Ave.  
Sawtell  
NSW  
2452  
Ph: 02 66581733

Reid Technology  
Unit D, 15-17 Saturn Place  
North Harbour  
Auckland 1330  
New Zealand  
Ph: 9 489-8100  
Fax: 9 489-8585  
[psands@reidtechnology.co.nz](mailto:psands@reidtechnology.co.nz)



Suite 5, 20 Fletcher Road Mooroolbark Victoria 3138 Australia

Phone +61 3 9727 6600 Fax +61 3 9727 6601

Web [www.selectronic.com.au](http://www.selectronic.com.au) Email [sales@selectronic.com.au](mailto:sales@selectronic.com.au)