

# SG2500/3000HV-30

Outdoor Inverter for 1500 Vdc System



NEW

## HIGH YIELD

- Advanced three-level technology, max. inverter efficiency 99 %
- Effective cooling, full power operation at 50 °C

## SMART O&M

- Integrated zone monitoring function for online analysis and trouble shooting
- Modular design, easy for maintenance
- Convenient external touch screen

## SAVED INVESTMENT

- Low transportation and installation cost due to outdoor design
- DC 1500 V system, low system cost
- Q at night function optional

## GRID SUPPORT

- Compliance with standards: IEC 61727, IEC 62116
- Low / High voltage ride through (L/HVRT)
- Active & reactive power control and power ramp rate control

## CIRCUIT DIAGRAM

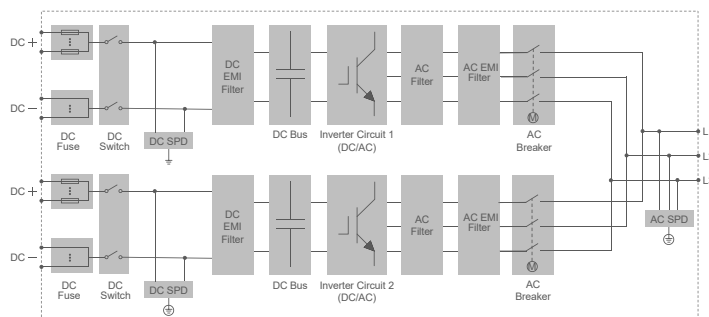

## EFFICIENCY CURVE(SG3000HV-30)

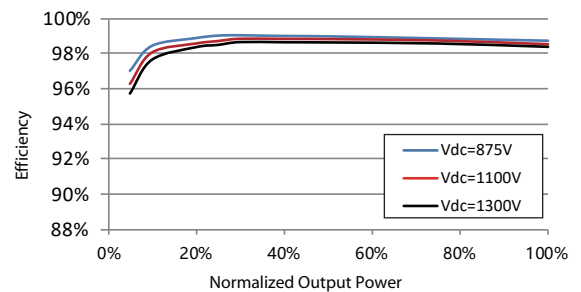

Type designation	SG2500HV-30	SG3000HV-30
<b>Input (DC)</b>		
Max. PV input voltage	1500 V	
Min. PV input voltage / Startup input voltage	800 V / 840 V	875 V / 915 V
MPP voltage range	800 – 1300 V	875 – 1300 V
No. of independent MPP inputs	2	
No. of DC inputs	18(optional: 22/24 inputs negative grounding or floating; 28 inputs negative grounding)	
Max. PV input current	3508 A	3500 A
Max. DC short-circuit current	10000 A	
PV array configuration	Negative grounding or floating	
<b>Output (AC)</b>		
AC output power	2750 kVA @ 45 °C, 2500 kVA @ 50 °C	3000 kVA @ 50 °C
Max. AC output current	2887 A	
Nominal AC voltage	550 V	600 V
AC voltage range	467 – 605 V	510 – 660 V
Nominal grid frequency / Grid frequency range	50 Hz / 45 – 55 Hz, 60 Hz / 55 – 65 Hz	
Harmonic (THD)	< 3 % (at nominal power)	
Power factor at nominal power / Adjustable power factor	> 0.99 / 0.8 leading – 0.8 lagging	
Feed-in phases / AC connection	3 / 3-PE	
<b>Efficiency</b>		
Max. efficiency / European efficiency	99.0 % / 98.7 %	
<b>Protection &amp; Function</b>		
DC input protection	Load break switch + fuse	
AC output protection	Circuit breaker	
Overvoltage protection	DC Type I + II / AC Type II	
Grid monitoring / Ground fault monitoring	Yes / Yes	
Insulation monitoring	Yes	
Surge protection	Yes	
Q at night function	Optional	
<b>General Data</b>		
Dimensions (W*H*D)	2280 * 2280 * 1600 mm	
Weight	3.2 T	
Topology	Transformerless	
Degree of protection	IP65	
Night power consumption	< 200 W	
Operating ambient temperature range	-35 to 60 °C (> 50 °C derating)	
Allowable relative humidity range	0 – 100 %	
Cooling method	Temperature controlled forced air cooling	
Max. operating altitude	4000 m (> 3000 m derating)	
Display	Touch screen	
Communication	Standard: RS485, Ethernet	
Compliance	CE, IEC 62109, IEC 61727, IEC 62116	
Grid support	Q at night function (optional), L/HVRT, active & reactive power control and power ramp rate control	

